

Bimba Metric Flat Cylinders

BIMBA FLAT-1 FITS RIGHT IN!

BIMBA Flat-1 cylinders were designed with space savings in mind. Five models offer five ways to save space.

- Flat-1, the original round cylinder
- Square Flat-1, for additional mounting variations
- Flat-II, the round, dual piston rod, nonrotating cylinder
- Square Flat-II, the square, dual piston rod, nonrotating cylinder
- FM2/FM3/FM4 for two, three, or four times the force in a single cylinder
- FMP for three positions

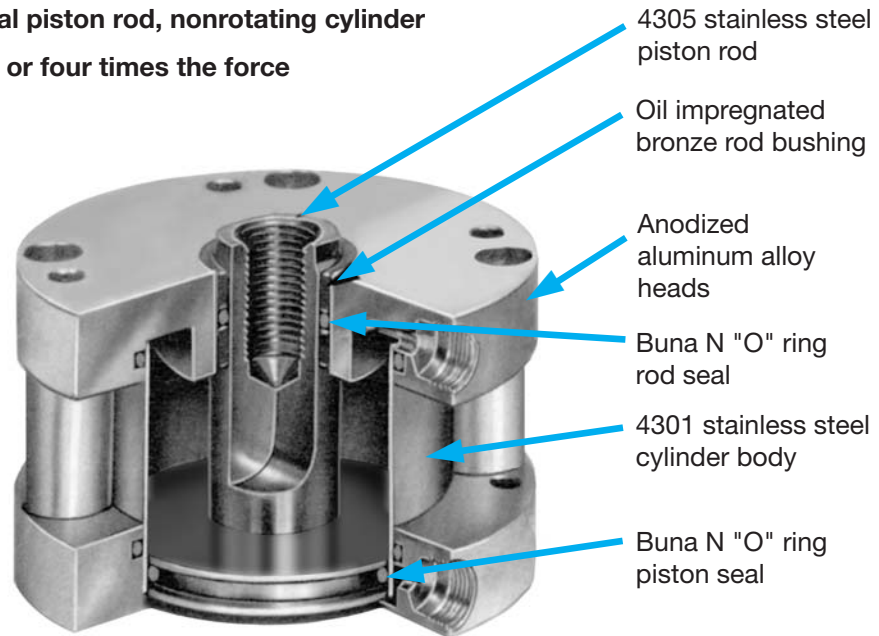

Space savings without sacrificing quality means better performance and longer cylinder life. Flat-1 offers these quality features:

- 4301 stainless steel (X5 CrNi 18.9) cylinder body with a mirror finish I.D. Stainless steel fights corrosion and scoring from dirt particles. The result is longer piston seal life.
- Oil impregnated bronze rod bushing is standard in all models. No sacrifice of bushing length to save space.
- Ground and polished 4305 stainless steel (X12 CrNi 18.8) piston rod.
- High strength piston to rod connection.
- Precision machined, anodized aluminum alloy heads.

Approximate Power Factors (For all models except FM2, FM3, FM4)

14mm	=	15 N/bar
19mm	=	28 N/bar
27mm	=	57 N/bar
38mm	=	113 N/bar
50mm	=	196 N/bar
63mm	=	311 N/bar
76mm	=	453 N/bar
101mm	=	801 N/bar

For example, a 14mm bore model FM-0225 will exert a force of approximately 75N when the supply pressure is 5 bar.



- Body — 4301 Stainless Steel
- Heads — Anodized Aluminum Alloy
- Piston Rod — Ground and Polished 4305 Stainless Steel
- Seals — Buna N (High temperature seals optional)
- Rod Bushing — Oil Impregnated Bronze
- Spring Forces — See Page 3.7
- Pressure Rating — 14 Bar Maximum (Air only)
- Temperature Rating — From -25°C to +65°C

Buna N seals with a temperature range of -25°C to +65°C are standard in all Bimba air cylinders. Fluoroelastomer seals rated for higher temperature applications are available. If cylinders are operated below -18°C for extended time periods, special modifications may be required. Special seal materials are available upon request.

How to Order

The Model Number for all Flat-1 cylinders consists of three alphanumeric clusters. These designate type, bore size and stroke length, and mounting and special options. Please refer to the charts below for an example of Model Number FM-1715-3V. This is a double acting, 38mm bore, 15mm stroke cylinder with threaded mounting holes both ends and high temperature option.

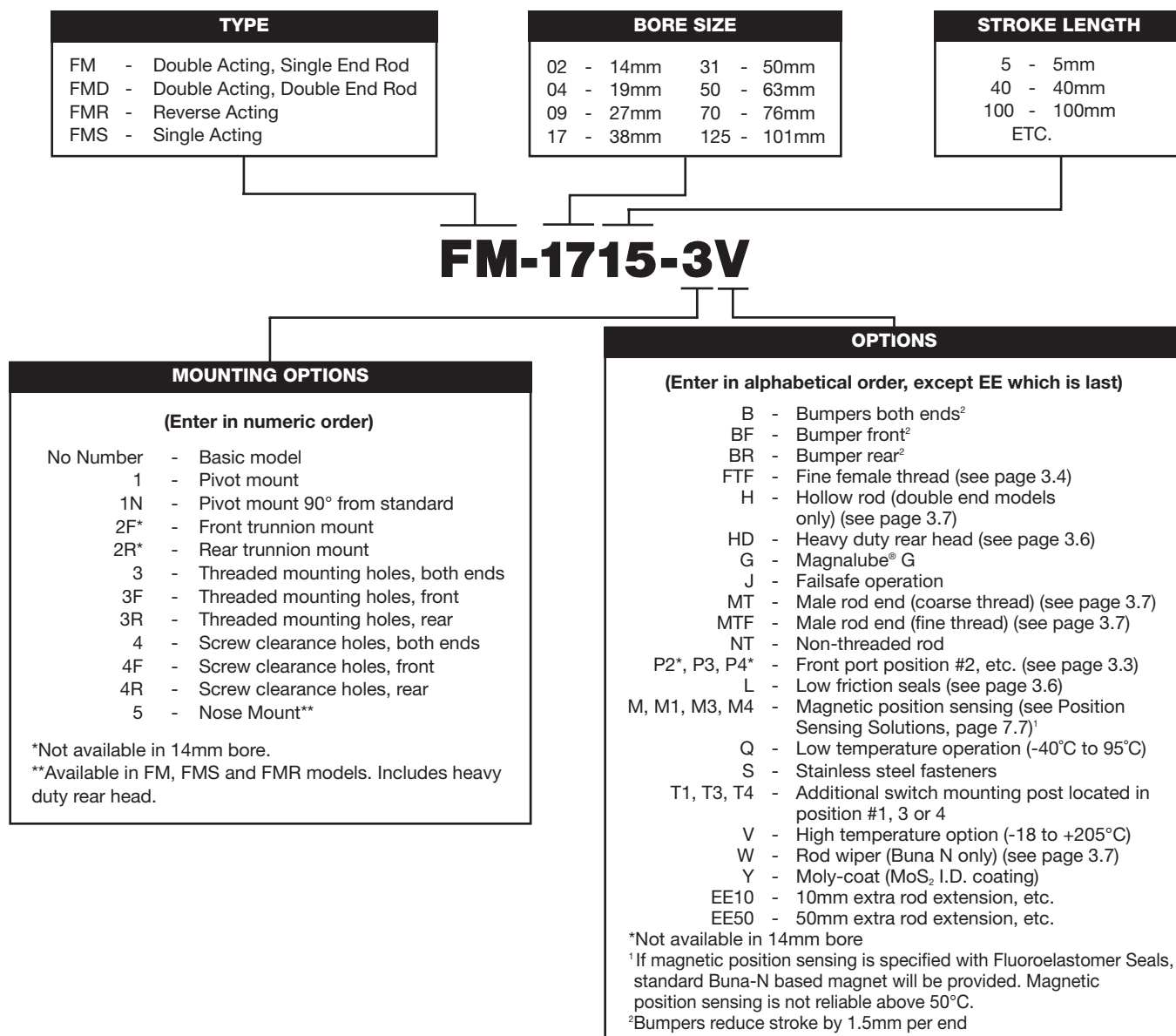

Magnalube® is a trademark of Carleton-Stuart Company.

Basic Models

Model FM

(Double Acting, Single End Rod)

Standard strokes
3.2mm, 5, 10, 15, 20, 25, 30, 40, 50, 80, 100mm

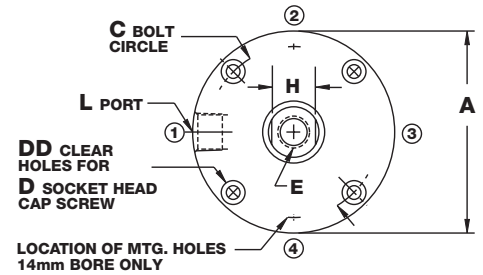
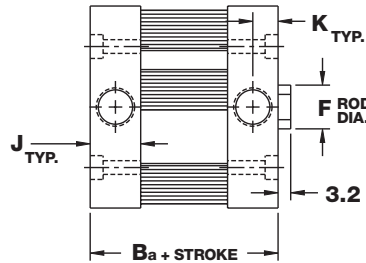

ISO 6431

ISO 6432

Model FMD

(Double Acting, Double End Rod)

Standard strokes
3.2mm, 5, 10, 15, 20, 25, 30, 40, 50, 80, 100mm

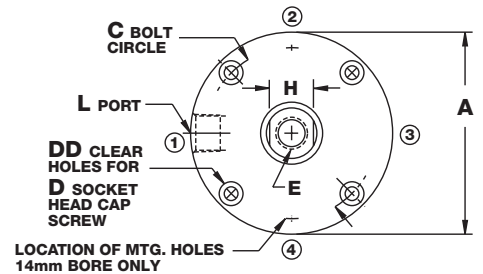
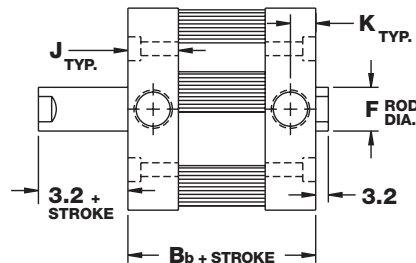

Flat

Pneu-Turn

Model FMS

(Single Acting, Spring Return, Rod Normally Retracted)

Standard strokes
3.2mm, 5, 10, 15, 20, 25, 30, 40, 50mm

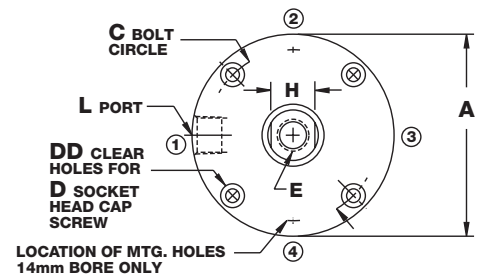
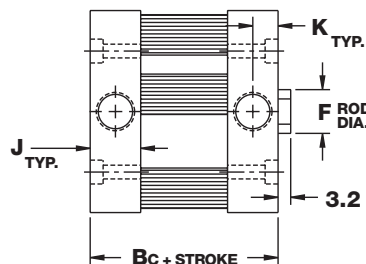

Ultram

Contact Distributor for price and dimensions over 50mm stroke. See page 3.7 for spring forces.

Model FMR

(Reverse Acting, Spring Return, Rod Normally Extended)

Standard strokes
3.2mm, 5, 10, 15, 20, 25, 30, 40, 50mm

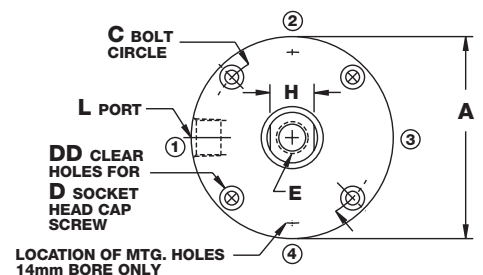
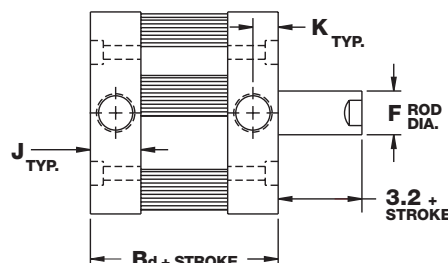

Flow Control

Position Sensing Solutions

Contact Distributor for price and dimensions over 50mm stroke. See page 3.7 for spring forces.

Dimensions(mm)

(Basic Model)

Bore	A	Ba*	Bb*	Bc*		Bd*		C	DD	D	E Std.
				0-25mm	26-50mm	0-25mm	26-55mm				
14mm (02)	28.5	14.3	17.4	20.6	34.9	27.0	41.3	22.5	2	M3	M4
19mm (04)	38.0	14.3	17.4	20.6	34.9	27.0	41.3	31.0	4	M3	M5
27mm (09)	50.6	22.2	23.8	22.2	38.1	34.9	50.8	43.0	4	M3	M8
38mm (17)	66.4	22.2	25.4	22.2	38.1	34.9	50.8	56.0	4	M5	M10
50mm (31)	79.1	23.8	27.0	23.8	39.7	36.5	52.4	68.0	4	M5	M12
63mm (50)	95.0	30.2	33.3	30.2	52.4	49.2	88.9	83.0	4	M6	M12
76mm (70)	107.7	31.8	34.9	31.8	54.0	50.8	73.0	96.0	4	M6	M16
101mm (125)	139.5	39.7	42.9	39.7	61.9	58.7	81.0	125.0	4	M8	M20

Bore	E Fine	E Depth	F	H	J	K	L
14mm (02)	M4x0.5	11.7	6.3	5.5	8.7	3.6	M5
19mm (04)	M5x0.5	11.7	7.9	6.0	8.7	3.6	M5
27mm (09)	M8x1.0	17.8	12.7	11.0	12.7	6.4	G 1/8
38mm (17)	M10x1.25	17.8	15.9	12.0	12.7	6.4	G 1/8
50mm (31)	M12x1.25	17.8	19.1	16.0	13.5	6.4	G 1/8
63mm (50)	M12x1.25	17.8	19.1	16.0	16.7	8.3	G 1/8
76mm (70)	M16x1.5	18.5	22.2	19.0	17.5	8.3	G 1/8
101mm (125)	M20x1.5	20.3	25.4	22.0	21.4	10.7	G 1/4

*See page 3.6 for length adders for options.

Mounting Options

Trunnion Mount

(rear or front)
(-2F shown)
Not available in 14mm bore.

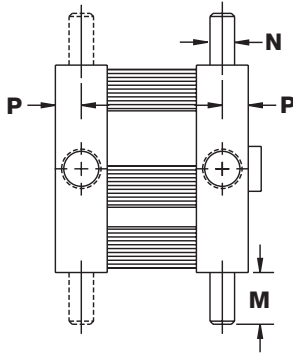

Pivot Mount

(-1 shown)
Complete with bronze pivot bushing.
Not available as an accessory.

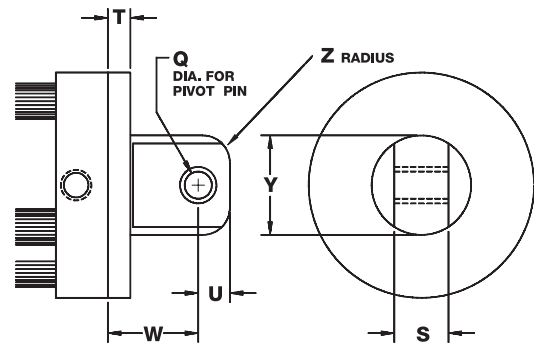

Threaded Mounting Holes

(available either or both ends)
(-3R shown)
14mm Bore

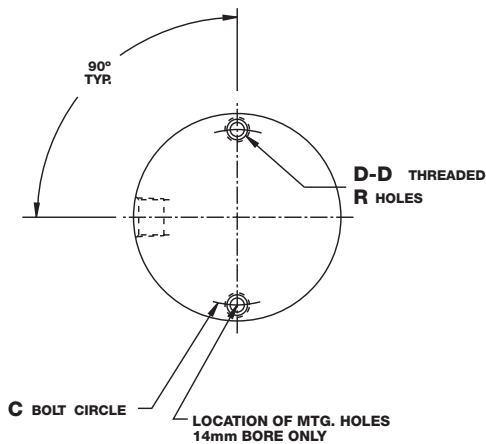

19mm Bore and larger

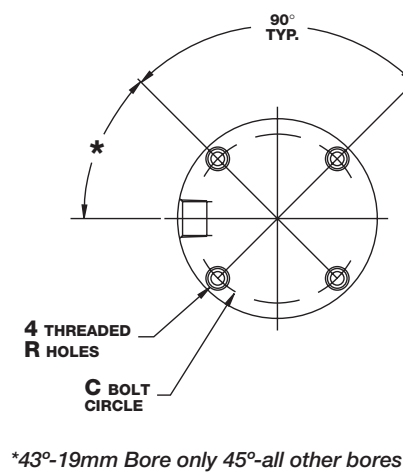

Nose Mount

(available in FM, FMS, FMR)
(-5 shown)
Includes heavy duty rear head; see page 3.6

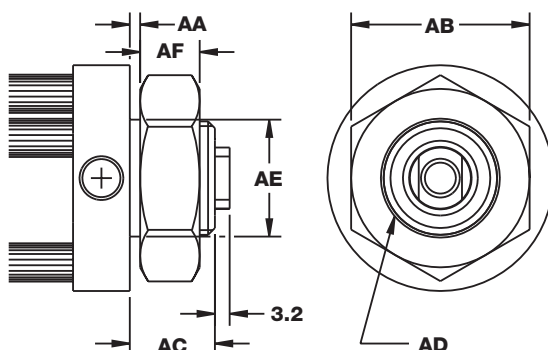

Screw Clearance Holes

(available either or both ends)
(-4R shown)

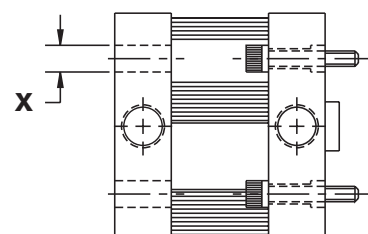

ISO 6431

ISO 6432

Flat

Pneu-Turn

Ultra

Flow Control

Position
Sensing Solutions

Dimensions(mm)

(Nose Mount)

Bore	AA	AB	AC	AD	AE	AF
14mm (02)	1.52	24 Hex	9.65	M16 x 1.5 6g	12.70	6
19mm (04)	1.52	32 Hex	9.65	M22 x 1.5 6g	15.75	6
27mm (09)	3.30	46 Hex	19.05	M30 x 1.5 6g	25.40	8
38mm (17)	3.30	60 Hex	19.05	M38 x 1.5 6g	31.75	10
50mm (31)	4.83	70 Hex	22.35	M45 x 1.5 6g	35.05	10
63mm (50)	6.35	70 Hex	25.40	M45 x 1.5 6g	35.05	10
76mm (70)	6.35	80 Hex	25.40	M52 x 1.5 6g	35.05	12
101mm (125)	4.83	80 Hex	28.45	M52 x 1.5 6g	44.45	12

(Mounting Options)

Bore	M	N	P	Q	R	S	T	U	W	X	Y	Z
14mm (02)	N/A	N/A	N/A	5	M3	9.5	5	6.5	19	4.6	16	5
19mm (04)	8	3	4.5	5	M3	9.5	5	6.5	19	6	19	5
27mm (09)	13	6	6.5	5	M3	9.5	6.5	6.5	20.5	6	19	5
38mm (17)	13	6	6.5	10	M5	19	6.5	11.5	30	9	35	9.5
50mm (31)	13	6	6.5	10	M5	19	8	11	32	9	35	9.5
63mm (50)	16	8	8.5	10	M6	19	9.5	11	33.5	10.5	35	9.5
76mm (70)	16	8	8.5	16	M6	25.5	9.5	14	43	10.5	47.5	9.5
101mm (125)	19	10	10.5	16	M8	25.5	11	14.5	44.5	13.5	47.5	9.5

Maximum Torque Recommendations (N-m)

Bore	Maximum Torque
14mm (02)	16
19mm (04)	38
27mm (09)	136
38mm (17)	163
50mm (31)	176
63mm (50)	176
76mm (70)	176
101mm (125)	203

NOTE: Exceeding recommended torque may cause mounting threads to shear.

Options

(Dimensional variations from standard as shown.)

Bore	Length Adder				
	Low Friction Seals (L)	Heavy Duty Rear Head* (HD)	Magnetic Position Sensing**		
			FM, FMD	FMS	FMR
14mm (02)	6.4	3.2	22.2	15.9	9.5
19mm (04)	6.4	3.2	22.2	22.2	22.2
27mm (09)	9.5	4.8	22.2	22.2	22.2
38mm (17)	9.5	4.8	22.2	22.2	22.2
50mm (31)	9.5	4.8	22.2	22.2	22.2
63mm (50)	9.5	6.4	22.2	22.2	22.2
76mm (70)	12.7	6.4	22.2	22.2	22.2
101mm (125)	12.7	9.5	22.2	22.2	22.2

**Heavy duty rear head is recommended for applications where the cylinder is mounted on the front face or trunnion-mounted, and impact loading (20 or more cycles per minute) occurs between the piston and rear head. It increases the overall length of the cylinder as shown.*

***A minimum stroke of 9.5mm is required to sense extending end-of-stroke position. For low friction seals used in conjunction with magnetic position sensing, use M length adder only.*

Options(mm)

Rod Wiper (Option W)

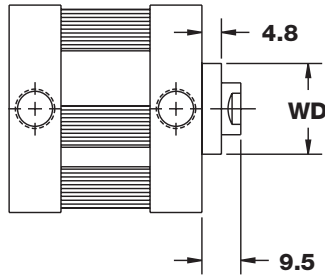

Bore	WD
14mm (02)	14.3
19mm (04)	17.5
27mm (09)	22.2
38mm (17)	25.4
50mm (31) 63mm (50)	28.6
76mm (70)	31.8
101mm (125)	34.9

Male Rod Ends (Option MT or MTF)

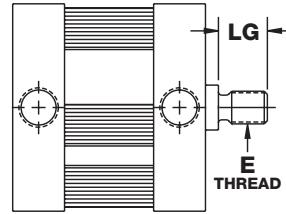

Bore	E		LG
	MT	MTF	
14mm (02)	M4	M4 x 0.5	10
19mm (04)	M5	M5 x 0.5	10
27mm (09)	M8	M8 x 1.0	12
38mm (17)	M10	M10 x 1.25	12
50mm (31) 63mm (50)	M12	M12 x 1.25	16
76mm (70)	M16	M16 x 1.5	20
101mm (125)	M20	M20 x 1.5	20

FMD Hollow Rods (Option H)

Bore	Hole Diameter	
	Female Rod Threads	Male Rod Threads
14mm (02)	3.2	N/A
19mm (04)	3.6	2.4
27mm (09)	5.6	4.0
38mm (17)	7.1	4.8
50mm (31) 63mm (50)	9.5	6.4
76mm (70)	11.1	7.9
101mm (125)	12.7	9.5

Enclosed Spring Forces

Bore	Maximum Load	Spring Rate	
		1-25mm stroke	26-50mm stroke
14mm (02)	25N	.74 N/mm	.30 N/mm
19mm (04)	45N	1.05 N/mm	.44 N/mm
27mm (09)	50N	1.05 N/mm	.44 N/mm
38mm (17) 50mm (31)	57N	.95 N/mm	.39 N/mm
63mm (50) 76mm (70) 101mm (125)	110N	1.13 N/mm	.48 N/mm

ISO 6431

ISO 6432

Flat

Pneu-Turn

Ultran

Flow Control

Position Sensing Solutions

Repair Parts

Single End Rod Kits

Basic Repair Kit (K-B-FO)*		
Part No.	Description	Quantity
PF-1	Rod Seal	1
PF-2	Piston Seal	1
PF-3	Tube Seal	2
PF-4	Bushing	2
Wiper Option Basic Repair Kit (K-B-FO-W)*		
Part No.	Description	Quantity
PF-1	Rod Seal	1
PF-2	Piston Seal	1
PF-3	Tube Seal	2
PF-4	Bushing	1
PF-5	Wiper Bushing	1
PF-6	Wiper	1

Double End Rod Kits

Basic Repair Kit (K-B-FOD)*		
Part No.	Description	Quantity
PF-1	Rod Seal	2
PF-2	Piston Seal	1
PF-3	Tube Seal	2
PF-4	Bushing	2
Wiper Option Basic Repair Kit (K-B-FOD-W)*		
Part No.	Description	Quantity
PF-1	Rod Seal	2
PF-2	Piston Seal	1
PF-3	Tube Seal	2
PF-5	Wiper Bushing	2
PF-6	Wiper	2

**Must specify bore size when ordered. Contact your local BIMBA Distributor for pricing on kits and other repair parts.*

Single End Rod Kits for Nose Mount Option

Basic Repair Kit (K-B-FO-N)		
Part No.	Description	Quantity
PF-1	Rod Seal	1
PF-2	Piston Seal	1
PF-3	Tube Seal	2
PF-4	Bushing	2
Wiper		
D-63632	14mm (02)	1
D-63633	19mm (04)	1
D-63634	27mm (09)	1
D-63635	38mm (17)	1
D-63636	50mm (31), 63mm (50)	1
D-63637	76mm (70)	1
D-63638	101mm (125)	1

Mounting Nuts	
Bore	Part No.
14mm (02)	D-62752
19mm (04)	D-62753
27mm (09)	D-62754
38mm (17)	D-62755
50mm (31)	D-62756
63mm (50)	D-62756
76mm (70)	D-62785
101mm (125)	D-62785

Weights

Bore	Approximate Cylinder Weights (gms)							
	FM, FMS		FMD			FMR		Nose Mount option
	Base	Adder per 5mm of stroke	Base	Adder per 5mm of stroke	Adder per 5mm of stroke for -H option	Base	Adder per 5mm of stroke	Adder to base weight
14mm (02)	34	3.6	37	6.8	4.4	36.9	3.6	5
19mm (04)	54	4.4	60	9	6.8	56.7	4.4	10
27mm (09)	139	13.4	164	17.8	13.4	150.3	13.4	40
38mm (17)	272	17.8	318	26.7	22.3	297.7	17.8	70
50mm (31)	369	22.3	431	31.1	26.7	396.9	22.3	120
63mm (50)	635	26.7	794	35.5	31.1	708.7	26.7	130
76mm (70)	819	35.5	1077	49	40.1	921.4	35.5	180
101mm (125)	1579	44.6	2036	58	49	1752.0	44.6	210

The convenient alternative for horizontal and side mounting, with provisions for both a bottom flush or face mounting. The Square Flat-1 also minimizes the centerline distance when cylinders are mounted side-by-side.



- Body — 4301 Stainless Steel
- Heads — Anodized Aluminum Alloy
- Piston Rod — Ground and Polished 4305 Stainless Steel
- Seals — Buna N (High temperature seals optional)
- Rod Bushing — Oil Impregnated Bronze
- Tie Rods — 4305 Stainless Steel
- Spring Forces — See Page 3.13
- Pressure Rating — Bore Sizes 19mm-50mm 14 Bar Maximum (Air only)
Bore Sizes 63mm-101mm 10.34 Bar Maximum (Air only)
- Temperature Rating — From -25°C to +65°C. Buna N seals with a temperature range of -25°C to +65°C are standard in all Bimba air cylinders. Fluoroelastomer seals rated for higher temperature applications are available. If cylinders are operated below -18°C for extended time periods, special modifications may be required. Special seal materials are available upon request.

How to Order

The Model Number for all Square Flat-1 cylinders consists of three alphanumeric clusters. These designate type, bore size and stroke length, and options. Please refer to the charts below for an example of Model Number FSMS-7040-V. This is a single acting, 76mm bore, 40mm stroke cylinder with high temperature option.

TYPE	BORE SIZE	STROKE LENGTH
FSM - Double Acting, Single End Rod	04 - 19mm 50 - 63mm	5 - 5mm
FSMD - Double Acting, Double End Rod	09 - 27mm 70 - 76mm	40 - 40mm
FSMR - Reverse Acting	17 - 38mm 125 - 101mm	100 - 100mm
FSMS - Single Acting	31 - 50mm	ETC.

FSMS-7040-V

OPTIONS	
(Enter in alphabetical order, except EE which is last)	
B	- Bumpers both ends ²
BF	- Bumper front ²
BR	- Bumper rear ²
FTF	- Fine female thread (see page 3.11)
G	- Magnalube [®] G
J	- Failsafe operation
H	- Hollow rod (double end models only) (see page 3.13)
L	- Low friction seals (see page 3.12)
M, M1, M4	- Magnetic position sensing (see Position Sensing Solutions, page 7.7) ¹
MT	- Male rod end (coarse thread) (see page 3.12)
MTF	- Male rod end (fine thread) (see page 3.12)
NT	- Non-threaded rod
Q	- Low temperature operation (-40°C to 95°C)
S	- Stainless steel fasteners
T1, T4	- Additional switch track located in position #1 or 4
V	- High temperature option (-18 to +205°C)
W	- Rod wiper (Buna N only) (see page 3.12)
Y	- Moly-coat (MoS ₂ I.D. coating)
EE10	- 10mm extra rod extension, etc.
EE50	- 50mm extra rod extension, etc.

¹ If magnetic position sensing is specified with Fluoroelastomer Seals, standard Buna-N based magnet will be provided. Magnetic position sensing is not reliable above 50°C.
² Bumpers reduce stroke by 1.5mm per end

Magnalube[®] is a trademark of Carleton-Stuart Company.

ISO 6431

ISO 6432

Flat

Pneu-Turn

Ultran

Flow Control

Position Sensing Solutions

Basic Models

Model FSM

(Double Acting, Single End Rod)
Standard strokes

3.2mm, 5, 10, 15, 20, 25, 30, 40, 50, 80, 100m

*For C and DD dimensions with - M option, see page 3.20.

Bore sizes
19mm, 27mm,
38mm, 50mm

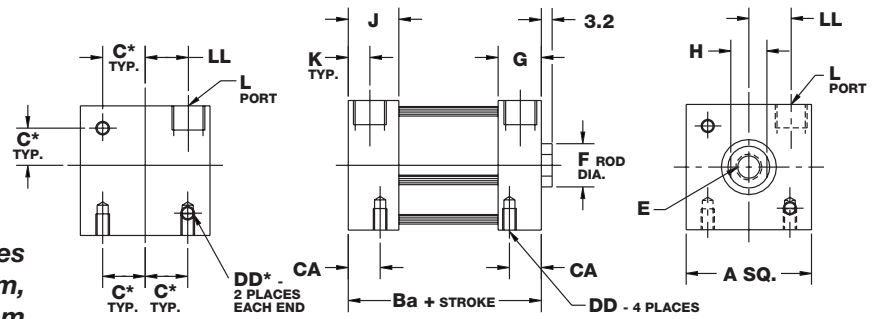

Bore sizes
63mm, 76mm,
101mm

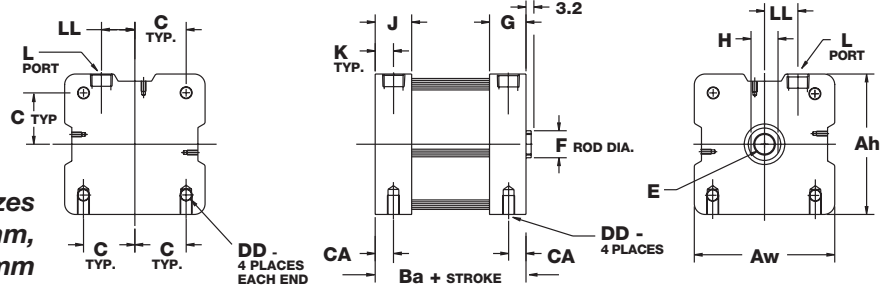

Model FSMD

(Double Acting, Double End Rod)
Standard strokes

3.2mm, 5, 10, 15, 20, 25, 30, 40, 50, 80, 100mm

*For C and DD dimensions with - M option, see page 3.20.

Bore sizes
19mm, 27mm,
38mm, 50mm

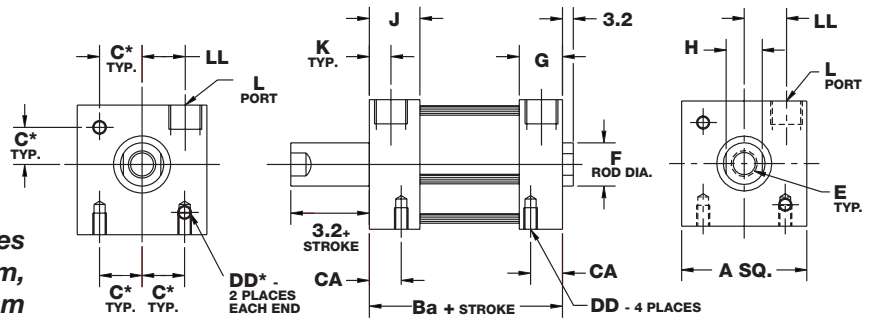

Bore sizes
63mm, 76mm,
101mm

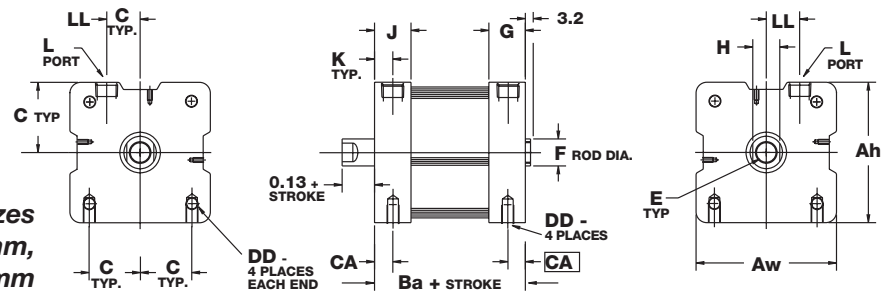

Model FSMS

(Single Acting, Spring Return, Rod Normally Retracted)
Standard strokes

3.2mm, 5, 10, 15, 20, 25, 30, 40, 50mm

Contact Distributor for price and dimensions over 50mm stroke. See page 3.13 for spring forces.

*For C and DD dimensions with - M option, see page 3.20.

Bore sizes
19mm, 27mm,
38mm, 50mm

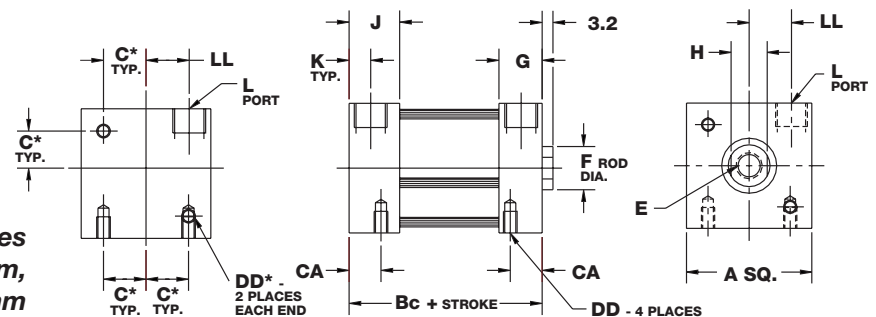

Basic Models

Model FSMS
(Continued)

Bore sizes
63mm, 76mm,
101mm

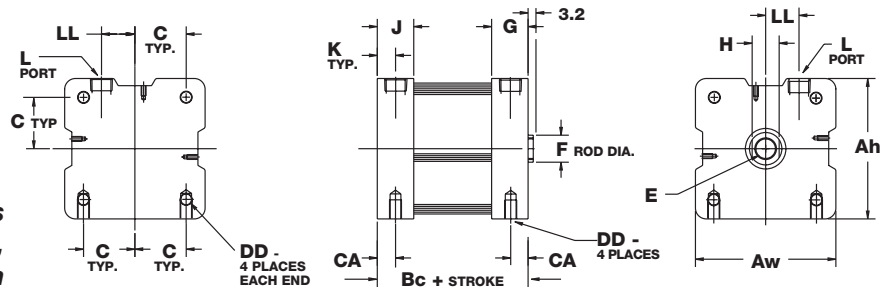

Model FSMR
(Reverse Acting,
Spring Return, Rod
Normally Extended)
Standard strokes

3.2mm, 5, 10, 15, 20,
25, 30, 40, 50mm

Bore sizes
19mm, 27mm,
38mm, 50mm

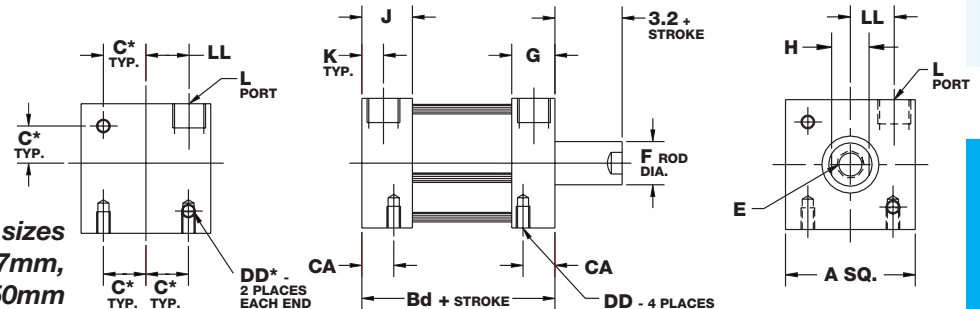

Contact Distributor for price
and dimensions over 50mm
stroke. See page 3.13 for
spring forces.

*For C and DD dimensions
with - M option, see page
3.20.

Bore sizes
63mm, 76mm,
101mm

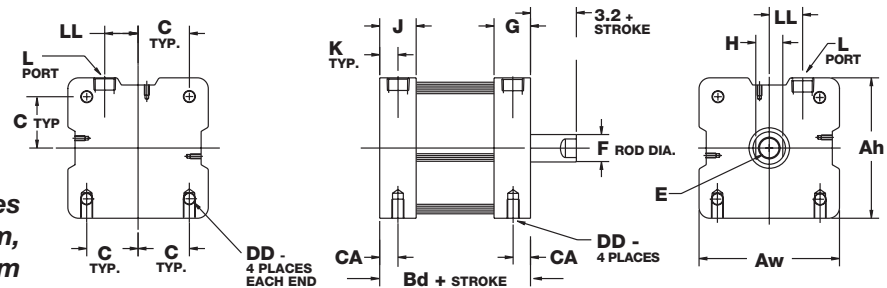

Dimensions(mm)

Bore	Aw	Ah	Ba*	Bc*		Bd*		C	CA	DD
				0-25mm	26-50mm	0-25mm	26-50mm			
19mm (04)	N/A	31.8	19.0	25.4	39.7	31.8	46.0	10.0	7.0	M4 x 0.7
27mm (09)	N/A	38.1	31.8	31.8	47.6	44.4	60.3	12.5	9.4	M4 x 0.7
38mm (17)	N/A	50.8	31.8	31.8	47.6	44.4	60.3	18.0	7.9	M5 x 0.8
50mm (31)	N/A	63.5	33.4	33.4	49.2	46.0	61.9	22.0	9.7	M6 x 1.0
63mm (50)	83.3	82.6	42.2	42.2	64.5	60.7	83.1	30.0	10.7	M8 x 1.25
76mm (70)	96.0	95.3	43.4	43.4	65.5	62.0	84.1	36.5	11.1	M8 x 1.25
101mm (125)	128.0	127.0	50.8	50.8	73.2	69.8	92.0	46.0	12.7	M12 x 1.75

Bore	E Standard	E Fine	E Depth	F	G	H	J	K	L	LL
19mm (04)	M5 x 0.8	M5 x 0.5	11.7	7.9	10.7	6.0	10.7	3.6	M5	7.5
27mm (09)	M8 x 1.25	M8 x 1.0	17.8	12.7	14.9	11.0	12.7	6.4	G 1/8	12.8
38mm (17)	M10 x 1.5	M10 x 1.25	17.8	15.9	14.6	12.0	12.7	6.4	G 1/8	17.5
50mm (31)	M12 x 1.75	M12 x 1.25	17.8	19.1	15.7	16.0	15.7	6.4	G 1/8	19.6
63mm (50)	M12	M12 x 1.25	17.8	19.1	21.4	16.0	21.4	10.7	G 1/8	19.7
76mm (70)	M16	M16 x 1.5	18.5	22.2	22.2	19.0	22.2	11.1	G 1/8	24.9
101mm (125)	M20	M20 x 1.5	20.3	25.4	25.4	22.0	25.4	12.7	G 1/4	31.8

* See page 3.12 for length adders for options.

ISO 6431

ISO 6432

Flat

Pneu-Turn

Ultra

Flow Control

Position
Sensing Solutions

Options(mm)

(Dimensional variations from standard as shown)

Bore	Length Adder		
	Low Friction Seals (L)	Magnetic Position Sensing* (M)	Low Friction Seals and Magnetic Position Sensing
19mm (04)	6.4	19.1	19.1
27mm (09)	9.5	12.7	12.7
38mm (17)	9.5	15.9	15.9
50mm (31)	9.5	15.9	15.9
63mm (50)	9.5	22.2	22.2
76mm (70)	12.7	22.2	22.2
101mm (125)	12.7	22.2	22.2

*A minimum stroke of 9.5mm is required to sense extending end-of-stroke position.

Rod Wiper (Option W)

(Buna N standard, not available in fluoroelastomer)

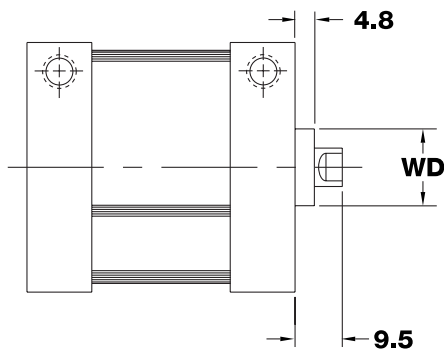

Bore	WD
19mm (04)	17.5
27mm (09)	22.2
38mm (17)	25.4
50mm (31)	28.6
63mm (50)	28.6
76mm (70)	31.8
101mm (125)	34.9

Male Rod Ends (Option MT or MTF)

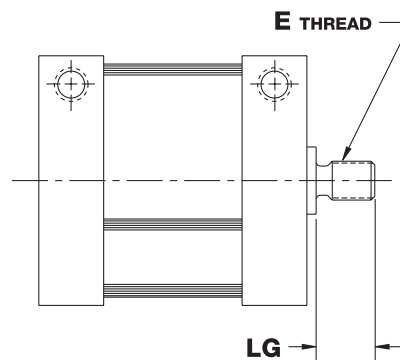

Bore	E		LG
	MT	MTF	
19mm (04)	M5	M5 x 0.5	10
27mm (09)	M8	M8 x 1.0	12
38mm (17)	M10	M10 x 1.25	12
50mm (31)	M12	M12 x 1.25	16
63mm (50)	M12	M12 x 1.25	16
76mm (70)	M16	M16 x 1.5	20
101mm (125)	M20	M20 x 1.5	20

Options(mm)

FSMD Hollow Rods (Option H)

Bore	Hole Diameter	
	Female Rod Threads	Male Rod Threads
19mm (04)	3.6	2.4
27mm (09)	5.6	4.0
38mm (17)	7.1	4.8
50mm (31)	9.5	6.4
63mm (50)	9.5	6.4
76mm (70)	11.1	7.9
101mm (125)	12.7	9.5

Enclosed Spring Forces

Bore	Maximum Load	Spring Rate	
		1-25mm stroke	26-50mm stroke
19mm (04)	45N	1.05 N/mm	.44 N/mm
27mm (09)	50N	1.05 N/mm	.44 N/mm
38mm (17) 50mm (31)	57N	0.95 N/mm	.39 N/mm
63mm (50)	110 N	1.13 N/mm	.48 N/mm
76mm (70)			
101mm (125)			

ISO 6431

ISO 6432

Flat

Pneu-Turn

Ultran

Flow Control

Position Sensing Solutions

Repair Kits

Single End Rod Kits

Basic Repair Kit (K-B-FS)*		
Part No.	Description	Quantity
PF-1	Rod Seal	1
PF-2	Piston Seal	1
PF-41	Tube Seal	2
PF-4	Bushing	2

Double End Rod Kits

Basic Repair Kit (K-B-FSD)*		
Part No.	Description	Quantity
PF-1	Rod Seal	2
PF-2	Piston Seal	1
PF-41	Tube Seal	2
PF-4**	Bushing	3

Wiper Option Basic Repair Kit (K-B-FS-W)*		
Part No.	Description	Quantity
PF-1	Rod Seal	1
PF-2	Piston Seal	1
PF-41	Tube Seal	2
PF-4	Bushing	1
PF-5	Wiper Bushing	1
PF-6	Wiper	1

Wiper Option Basic Repair Kit (K-B-FSD-W)*		
Part No.	Description	Quantity
PF-1	Rod Seal	2
PF-2	Piston Seal	1
PF-41	Tube Seal	2
PF-4**	Bushing	1
PF-5	Wiper Bushing	2
PF-6	Wiper	2

*Must specify bore size when ordered. Contact your local BIMBA Distributor for pricing on kits and other repair parts.

**Note: On FSMD (Double Acting, Double End Rod) models, two bushings are provided on the head end with tie rod nuts. Opposite head end has one bushing.

Weights

Bore	Approximate Cylinder Weights (gms)						
	FSM, FSMS		FSMD			FSMR	
	Base	Adder per 5mm of stroke	Base	Adder per 5mm of stroke	Adder per 5mm of stroke for -H option	Base	Adder per 5mm of stroke
19mm (04)	62	4.4	68	9	6.8	62	4.4
27mm (09)	145	9	162	17.8	13.4	155	9
38mm (17)	286	13.4	298	26.7	22.3	290	13.4
50mm (31)	403	17.8	454	35.5	26.7	425	17.8
63mm (50)	809	11.3	968	17	14.2	883	11.3
76mm (70)	1138	17	1395	25.5	19.8	1240	17
101mm (125)	2026	17	2482	25.5	19.8	2199	17



Flat-II nonrotating, double-acting cylinder provides the answer to applications where rotation cannot be tolerated and space is at a minimum. Nonrotation is achieved with dual piston rods and a rod end block that insures the rods work in tandem. Flat-II eliminates the need for external alignment devices, such as guides, rods and alignment posts or pins.

- Body — 4301 Stainless Steel
- Heads — Anodized Aluminum Alloy
- Piston Rod — Ground and Polished 4305 Stainless Steel
- Piston Seals — Buna N Block V (High temperature seals optional)
- Rod Bushing — Oil Impregnated Bronze
- Rod Seals — Buna N O-ring (High temperature seals optional)
- Tie Rods — 4305 Stainless Steel
- Rod End Block — Anodized Aluminum Alloy
- Pressure Rating — 14 Bar Maximum (Air only)
- Temperature Rating — From -25°C to +65°C

Buna N seals with a temperature range of -25°C to +65°C are standard in all Bimba air cylinders. Fluoroelastomer seals rated for higher temperature applications are available. If cylinders are operated below -18°C for extended time periods, special modifications may be required. Special seal materials are available upon request.

ISO 6431

ISO 6432

Flat

How to Order

The model number for Flat-II consists of three alphanumeric clusters. These designate type, bore size and stroke length, and mounting and special options. Please refer to the charts below for an example of Model Number FTM-0425-3CE. This is a nonrotating, double-acting, 19mm bore, 25mm stroke cylinder with threaded mounting holes both ends and counterbored mounting holes in the rod end block.

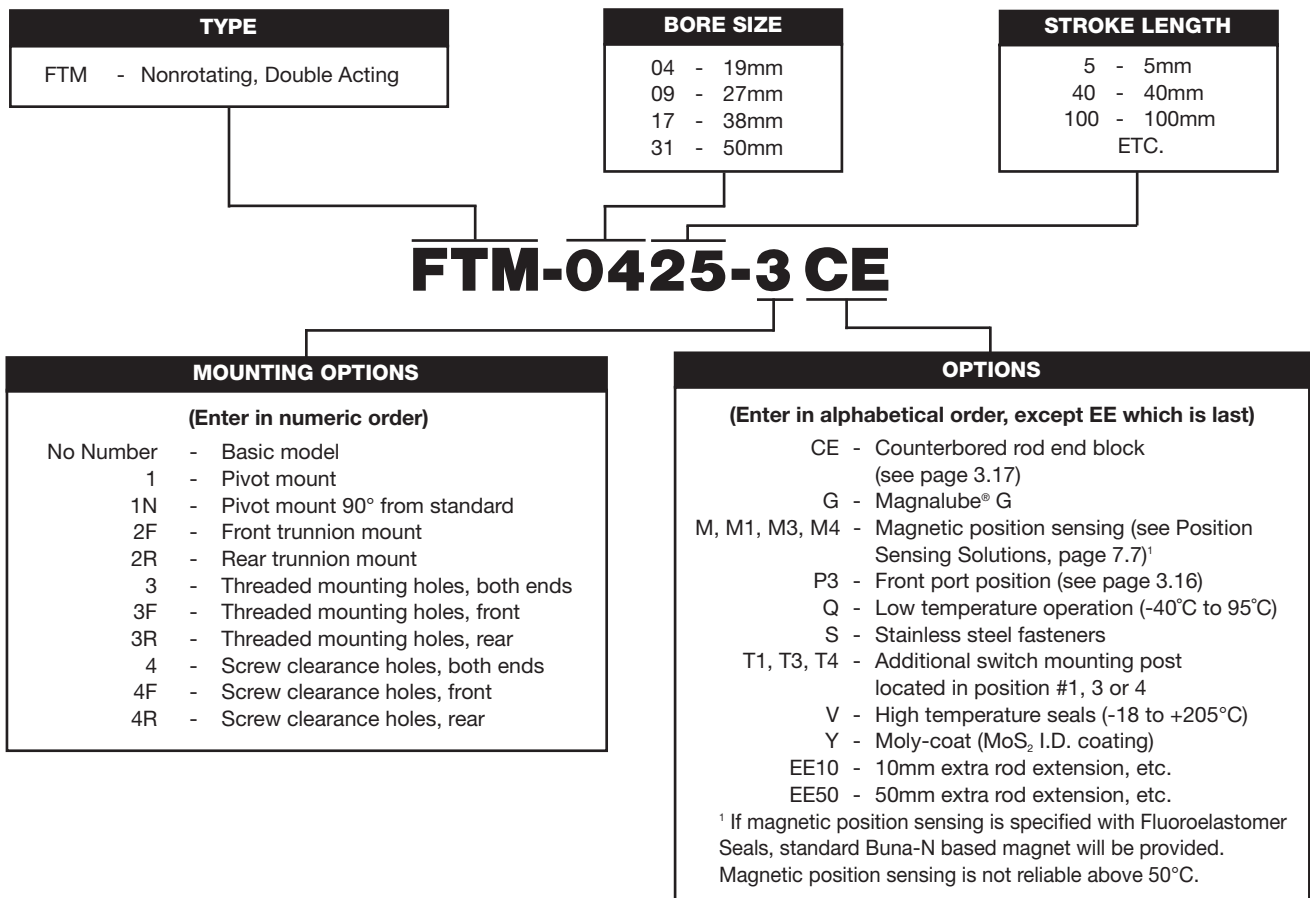

Pneu-Turn

Ultran

Flow Control

Position Sensing Solutions

Magnalube® is a trademark of Carleton-Stuart Company.

Basic Model

Model FTM

(Nonrotating, double acting)

Standard strokes

3.2mm, 5, 10, 15, 20, 25, 30,
40, 50, 80, 100mm

Longer strokes available
upon request

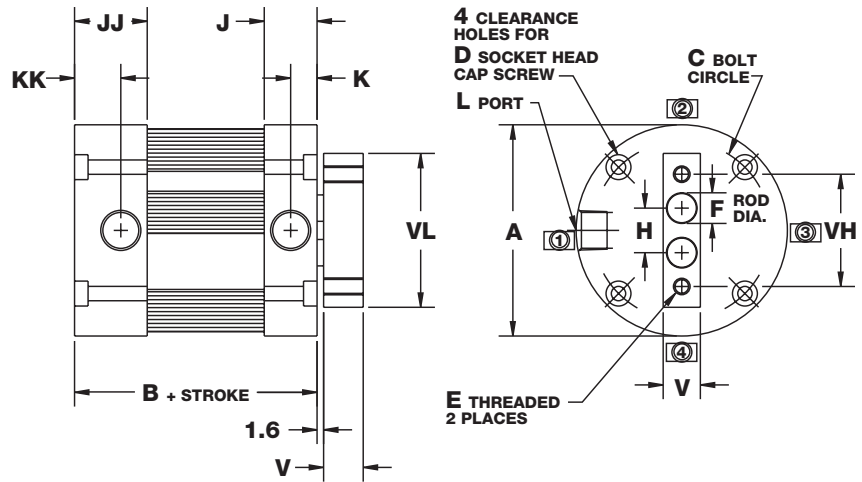

Mounting Options

Trunnion Mount

(rear or front)
(-2R shown)

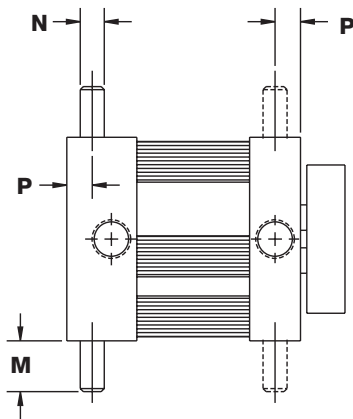

Pivot Mount

(complete with bronze bushing)
(-1 shown)

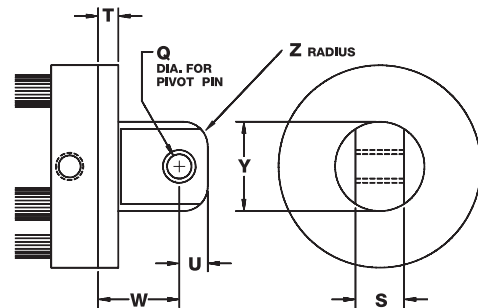

Threaded Mounting Holes

(available either or both ends)
(-3R shown)

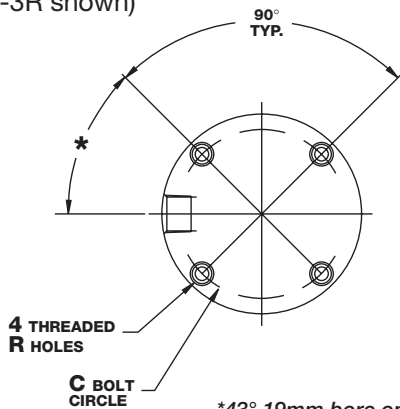

Screw Clearance Holes

(available either or both ends)
(-4R shown)

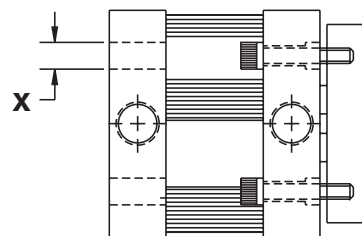

Counterbored Rod End Block

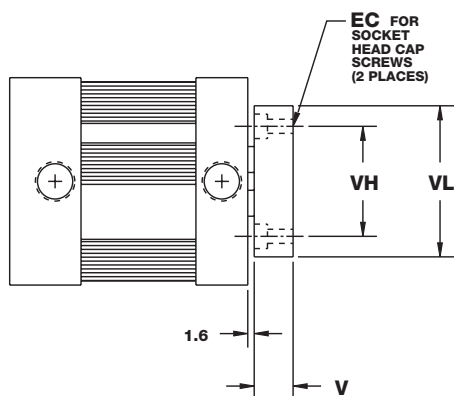

Dimensions(mm)

Bore	A	B*	C	D	E	EC	F	H
19mm (04)	38.0	23.8	31.0	M3	M3 x 0.5	M3	4.8	8.4
27mm (09)	50.6	33.3	43.0	M3	M4 x 0.7	M4	6.4	10.7
38mm (17)	66.4	33.3	56.0	M5	M6 x 1.0	M6	9.5	14.3
50mm (31)	79.1	34.9	68.0	M5	M8 x 1.25	M8	12.7	19.1

Bore	J	JJ	K	KK	L	M	N	P	Q	R
19mm (04)	8.7	11.9	3.6	6.8	M5	8	3	4.5	5	M3
27mm (09)	12.7	17.5	6.4	11.1	G 1/8	13	6	6.5	5	M3
38mm (17)	12.7	17.5	6.4	11.1	G 1/8	13	6	6.5	10	M5
50mm (31)	13.5	18.3	6.4	11.1	G 1/8	13	6	6.5	10	M5

Bore	S	T	U	V	VT	VL	VH	W	X	Y	Z
19mm (04)	9.5	5	6.5	9.0	9.5	30.0	22.0	19	6	19	5
27mm (09)	9.5	6.5	6.5	9.0	9.5	37.0	27.0	20.5	6	19	5
38mm (17)	19	6.5	11.5	12.0	12.7	51.0	38.0	30	9	35	9.5
50mm (31)	19	8	11	15.0	15.9	64.0	48.0	32	9	35	9.5

*Magnetic Position Sensing Length Adder: 15.9mm.
A minimum stroke of 9.5mm is required to sense extending end-of-stroke position.

ISO 6431

ISO 6432

Flat

Pneu-Turn

Ultran

Flow Control

Position Sensing Solutions

Nonrotation is achieved through the use of dual piston rods incorporated into the body of the Flat-II cylinder. The rods are securely attached to the piston by our unique spin-riveting process. A rod end block is used to insure the rods work in tandem—as a team. This end block also acts as a useful surface to easily accommodate any mounting attachments required to get the job done. For mounting convenience, the rod end block is provided with threaded mounting holes or optional counterbored holes.

As with any cylinder application, side loading should be avoided. The two smaller rods will have more deflection due to side load than the one standard rod in a comparable Flat-1 model.

The Flat-II is intended to work satisfactorily against pure torsional loads. The maximum torsional load per bore size is shown in the following table:

Bore	19mm (04)	27mm (09)	38mm (17)	50mm (31)
Torque (cm-kg)	0.35	1.15	5.77	11.55
K	85.38	436.06	3914.1	22034

The amount of angular deflection, in degrees, can be approximated by the following formula:

$$\Theta = \frac{TL^3}{K}$$

Where T = Torque (Cm.-Kg.)
 L = Length (see sketch below)
 K = Per chart above
 Θ = Angular deflection

Note: To prevent rod distortion, the rod end block must be fastened securely.

Rotational Tolerance

Bore	Maximum Rotation
19mm (04)	±1°
27mm (09)	±3/4°
38mm (17)	±1/2°
50mm (31)	±1/2°

Deflection L Value

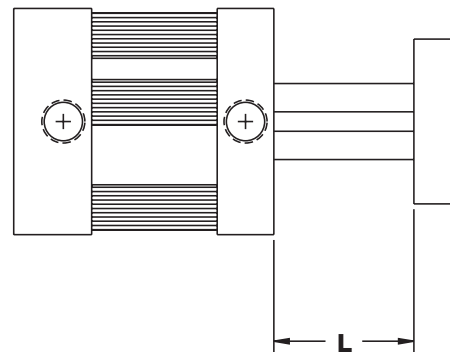

Repair Kits

Basic Repair Kit (K-B-FT)*		
Part No.	Description	Quantity
PF-29	Rod Seal	2
PF-30	Piston Seal	2
PF-3	Tube Seal	2
PF-31	Bushing	4

*Must specify bore size when ordered.
 Contact your local BIMBA Distributor for pricing on kits and other repair parts.

Weights

Bore	Approximate Cylinder Weights (gms)	
	Base	Adder per 5mm of stroke
19mm (04)	77	4.4
27mm (09)	181	22.3
38mm (17)	346	31.1
50mm (31)	522	40.1

Metric Square Flat-II nonrotating, double acting cylinder provides the answer to applications where rotation cannot be tolerated. Nonrotation is achieved with dual piston rods and a rod end block that insures the rods work in tandem. Square Flat-II eliminates the need for external alignment devices. It also provides a convenient alternative for horizontal and side mounting, with provisions for both bottom flush or face mounting. Centerline distances are minimized, facilitating side-by-side cylinder mounting.



- Body — 4301 Stainless Steel
- Heads — Anodized Aluminum Alloy
- Piston Rod — Ground and Polished 4305 Stainless Steel
- Piston Seals — Enhanced Lubricity Buna N (High temperature seals optional)
- Rod Bushing — Bronze
- Rod Seals — Buna N Block V (High temperature seals optional)
- Tie Rods — 4305 Stainless Steel
- Rod End Block — Anodized Aluminum Alloy
- Pressure Rating — 14 Bar Maximum (Air only)
- Temperature Rating — From -25°C to +65°C

Buna N seals with a temperature range of -25°C to +65°C are standard in all Bimba air cylinders. Fluoroelastomer seals rated for higher temperature applications are available. If cylinders are operated below -18°C for extended time periods, special modifications may be required. Special seal materials are available upon request.

How to Order

The Model Number for all Square Flat-II cylinders consists of three alphanumeric clusters. These designate type, bore size and stroke length and special options. Please refer to the charts below for an example of Model Number FSTM-1740-V. This is a nonrotating, double acting, 38mm bore, 40mm stroke cylinder, with high temperature option.

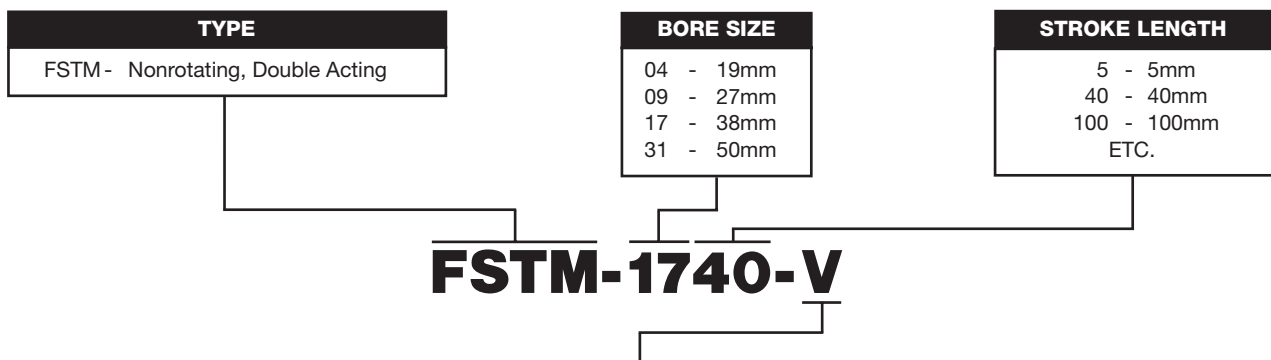

OPTIONS	
(Enter in alphabetical order, except EE which is last)	
CE	- Counterbored Endblock
G	- Magnalube®G
K	- Endblock rotated 90 degrees (see page 3.22)
L	- Low Friction Seals (see page 3.21)
M, M1, M4	- Magnetic Position Sensing (see Position Sensing Solutions, page 7.7) ¹
Q	- Low temperature operation (-40°C to 95°C)
S	- Stainless steel fasteners
T1, T4	- Additional switch track located in position #1 or 4
V	- High temperature seals (-18°C to 205°C)
Y	- Moly-coat (MoS ₂ I.D. coating)
EE10	- 10mm extra rod extension, etc.
EE50	- 50mm extra rod extension, etc.

¹ If magnetic position sensing is specified with Fluoroelastomer Seals, standard Buna-N based magnet will be provided. Magnetic position sensing is not reliable above 50°C.

Magnalube® is a trademark of Carleton-Stuart Company.

ISO 6431

ISO 6432

Flat

Pneu-Turn

Ultran

Flow Control

Position Sensing Solutions

Basic Model

Model FSTM

(Nonrotating, double acting)

Standard strokes

3.2mm, 5, 10, 15, 20, 25, 30, 40, 50, 80, 100mm

Longer strokes available upon request

*Cand DD dimensions apply to Square Flat-1 models with - M option in 19, 27, 38, and 50mm bore sizes).

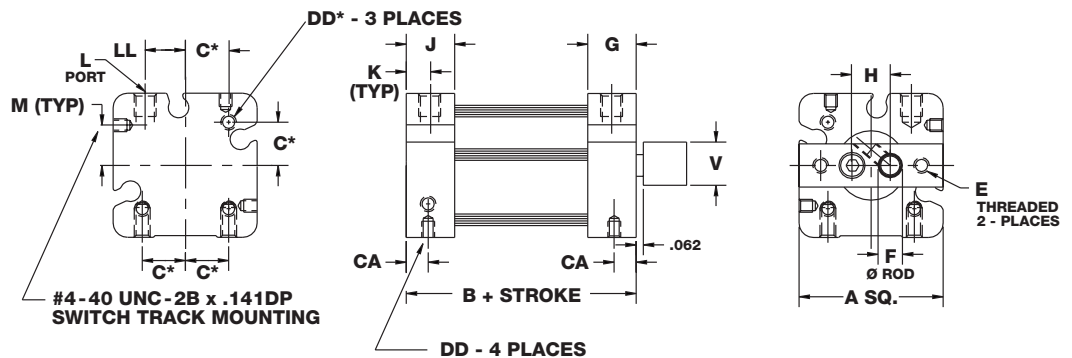

Counterbored Rod End Block

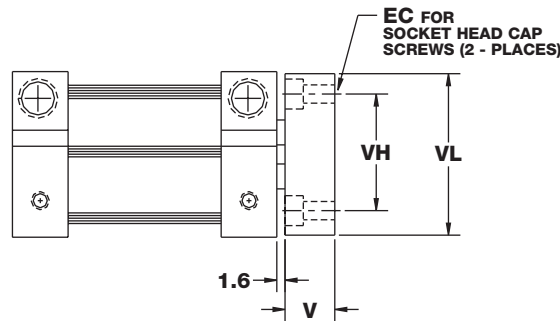

Dimensions (MM)

Bore	A	B	C	CA	DD	E	EC	F	G	H
19mm (04)	31.8	19	10.0	7.0	M4 x 0.7	M3 x 0.5	M3	4.8	10.7	8.4
27mm (09)	38.1	31.8	12.5	9.4	M4 x 0.7	M4 x 0.7	M4	6.4	14.9	10.7
38mm (17)	50.8	31.8	18.0	7.9	M5 x 0.8	M6 x 1.0	M6	9.5	14.6	14.3
50mm (31)	63.5	33.3	22.0	9.7	M6 x 1.0	M8 x 1.25	M8	12.7	15.7	19.1

Bore	J	K	L	LL	M	V	VH	VL
19mm (04)	10.7	4.8	M5	8.9	8.9	9.0	22.0	31.0
27mm (09)	12.7	6.4	G 1/8	10.7	8.2	9.0	27.0	37.0
38mm (17)	12.7	6.4	G 1/8	15.2	5.1	12.0	38.0	50.0
50mm (31)	15.7	6.4	G 1/8	19.3	4.7	15.0	48.0	63.0

A minimum stroke of 9.5mm is required to sense extending end-of-stroke position. See page 3.21 for length adders for magnet option.

Repair Kits

Basic Repair Kit (K-B-FSTM)*		
Part No.	Description	Quantity
PF-29-FSTM	Rod Seal	2
PF-30-FSTM	Piston Seal	1
PF-3-FSTM	Tube Seal	2

Weights

Bore	Approximate Cylinder Weights (grams)	
	Base	Adder per 5mm of stroke
19mm (04)	76	4.4
27mm (09)	181	22.3
38mm (17)	345	31.2
50mm (31)	467	40.0

Options

Bore	Length Adder		
	Low Friction Seals (L)	Magnetic Position Sensing* (M)	Low Friction Seals and Magnetic Position Sensing
19mm (04)	6.4	19	19
27mm (09)	9.7	12.7	12.7
38mm (17)	9.7	16	16
50mm (31)	9.7	16	16

*A minimum stroke of 9.5mm is required to sense extending end-of-stroke position.

ISO 6431

ISO 6432

Flat

Pneu-Turn

Ultran

Flow Control

Position Sensing Solutions

Nonrotation is achieved through the use of dual piston rods incorporated into the body of the Flat-II cylinder. The rods are securely attached to the piston by our unique spin-riveting process. A rod end block is used to insure the rods work in tandem—as a team. This end block also acts as a useful surface to easily accommodate any mounting attachments required to get the job done. For mounting convenience, the rod end block is provided with threaded mounting holes or optional counterbored holes.

As with any cylinder application, side loading should be avoided (see option K below). The two smaller rods will have more deflection due to side load than the one standard rod in a comparable Flat-1 model.

The Flat-II is intended to work satisfactorily against pure torsional loads. The maximum torsional load per bore size is shown in the following table:

Bore	19mm (04)	27mm (09)	38mm (17)	50mm (31)
Torque (cm-kg)	0.35	1.15	5.77	11.55
K	85.38	436.06	3914.1	22034

The amount of angular deflection, in degrees, can be approximated by the following formula:

$$\varnothing = \frac{TL^3}{K}$$

Where

- T = Torque (Cm.-Kg.)
- L = Length (see sketch below)
- K = Per chart above
- \varnothing = Angular deflection

Note: To prevent rod distortion, the rod end block must be fastened securely.

Rotational Tolerance

Bore	Maximum Rotation
19mm (04)	±1°
27mm (09)	±3/4°
38mm (17)	±1/2°
50mm (31)	±1/2°

Deflection L Value

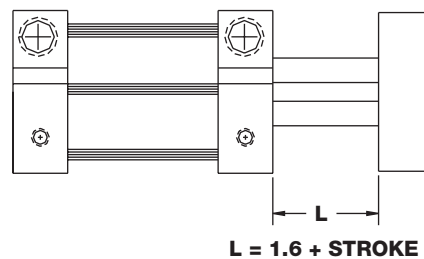

Option K - Endblock Rotated 90°

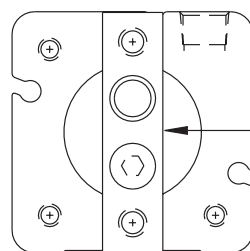

If side load cannot be avoided, the side load should be applied perpendicular to the plane formed by the two piston rods.



Space-Saving Cylinders That Multiply Force Output

The Bimba FM2, FM3, FM4 Series Flat-1 are double-acting, single end rod cylinders that multiply the force output by supplying air to multiple pistons on extension. They save space and eliminate the need for a higher pressure system. Only one piston is powered on the return stroke, saving air volume and operating costs.

- Body — 4301 Stainless Steel (X5 CrNi 18.9)
- Heads — Anodized Aluminum Alloy
- Piston Rod — Ground and Polished 4305 Stainless Steel (X12 CrNi 18.8)
- Seals — Buna N (High temperature seals optional)
- Rod Bushing — Oil Impregnated Bronze
- Pressure Rating — 7 Bar Maximum (Air only)
- Temperature Rating — From -25°C to +65°C

Buna N seals with a temperature range of -25°C to +65°C are standard in all Bimba air cylinders. Fluoroelastomer seals rated for higher temperature applications are available. If cylinders are operated below -18°C for extended time periods, special modifications may be required. Special seal materials are available upon request.

How it Works

Extension-air supplied to multiple pistons

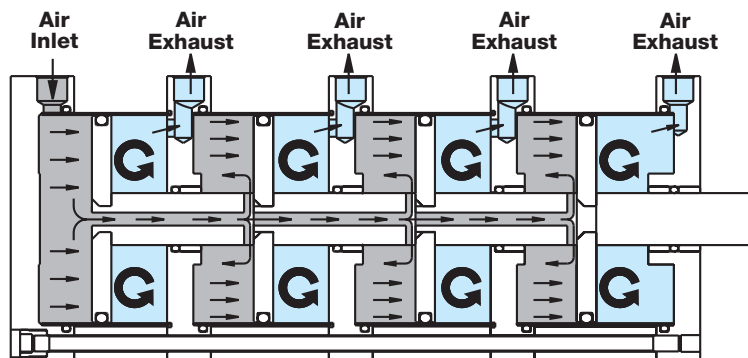

Retraction-air supplied to one piston only

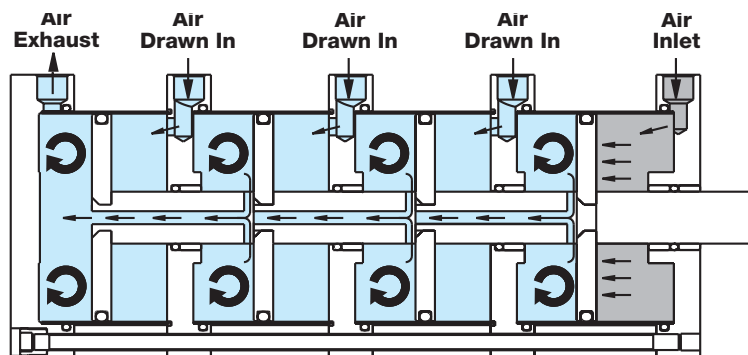

ISO 6431

ISO 6432

Flat

Pneu-Turn

Ultran

Flow Control

Position Sensing Solutions

How to Order

The model number for all FM2 Series Flat-1 cylinders consists of three alphanumeric clusters. These designate type, bore size and stroke length, and mounting and special options. Please refer to the charts below for our example of Model Number FM2-5025-3M. This is a 63mm bore FM2 Series Flat-1 with 25mm stroke, threaded mounting holes in both ends, with the magnetic position sensing option.

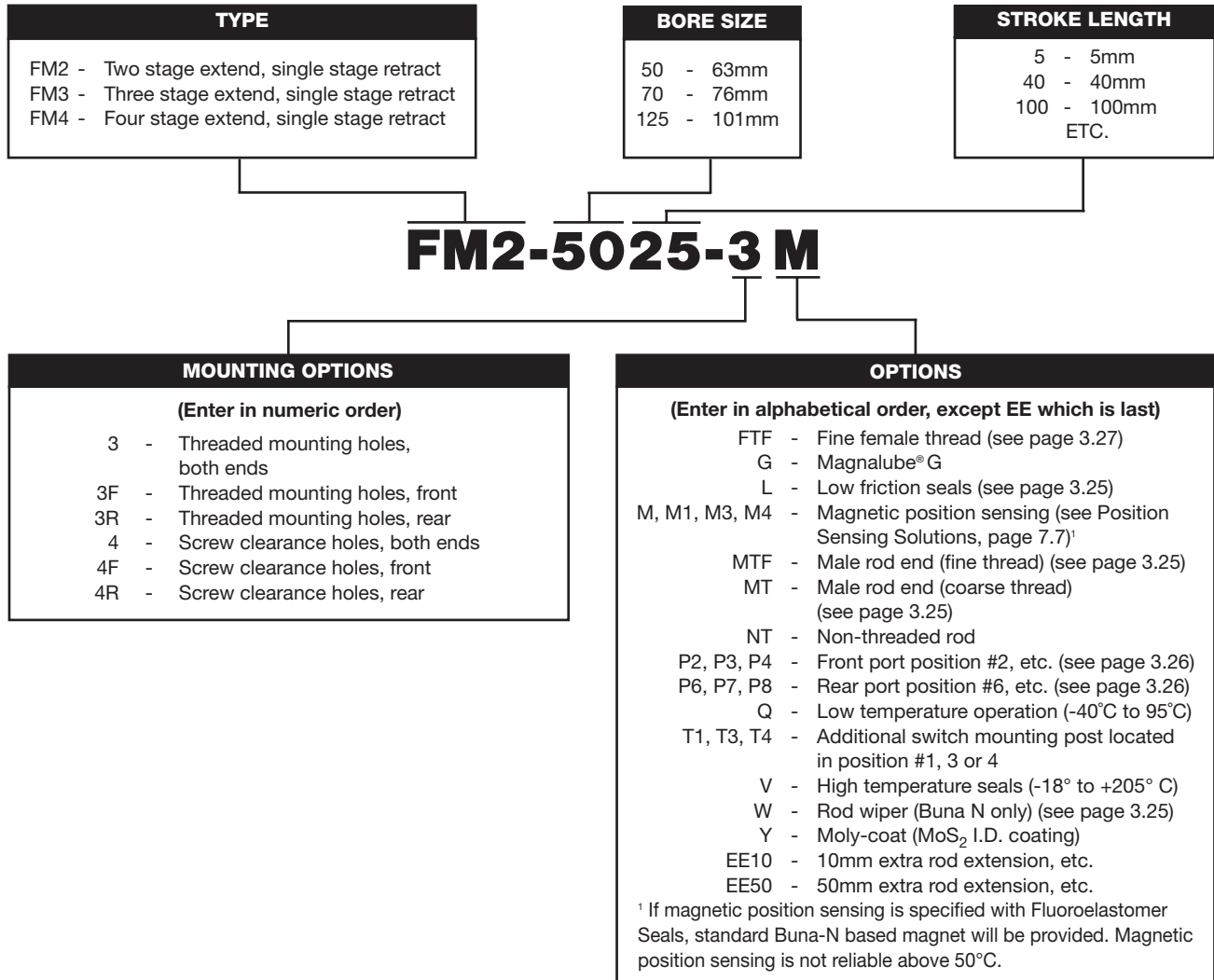

Magnalube® is a trademark of Carleton-Stuart Company.

Approximate Power Factors					
Bore	Bore Model Designator	Power Factor Extension			Power Factor Retraction
		FM2	FM3	FM4	
63mm (50)	50	606	890	1181	284
76mm (70)	70	871	1290	1710	413
101mm (125)	125	1568	2329	3091	755

Multiply the air line pressure by the power factor to get the approximate force. For example, an FM2-5025-3 operated at 6 bars will exert a force of 3636 N. on extension, and 1704 N. on retraction.

Options(mm)

(Dimensional variations from standard as shown)

Bore	Type	Length Adder		
		Low Friction Seal (L)	Magnetic Position Sensing* (M)	Low Friction Seal & Magnetic Position Sensing (LM)
63mm (50)	FM2	19.0	22.2	31.8
	FM3	28.7		41.4
	FM4	38.1		50.8
76mm (70)	FM2	25.4	22.2	35.1
	FM3	38.1		47.8
	FM4	50.8		60.5
101mm (125)	FM2	25.4	22.2	35.1
	FM3	38.1		47.8
	FM4	50.8		60.5

*A minimum stroke of 9.5mm is required to sense extending end-of-stroke position.

Rod Wiper (Option W)

(Buna N standard, not available in Viton)

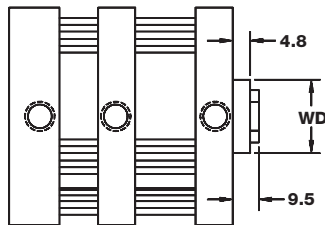

Bore	WD
63mm (50)	28.6
76mm (70)	31.8
101mm (125)	34.9

Male Rod Ends (Option MT or MTF)

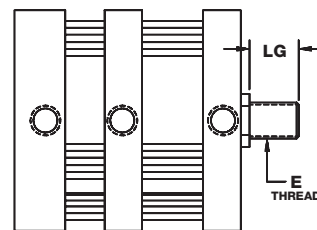

Bore	MT	MTF	LG
63mm (50)	M12	M12 x 1.25	16
76mm (70)	M16	M16 x 1.5	20
101mm (125)	M20	M20 x 1.5	20

ISO 6431

ISO 6432

Flat

Pneu-Turn

Ultran

Flow Control

Position Sensing Solutions

Basic Model

Standard strokes

3.2mm, 5mm, 10mm, 15mm, 20mm, 25mm, 30mm, 40mm, 50mm, 80mm, 100mm

Special strokes available on request

Model FM2

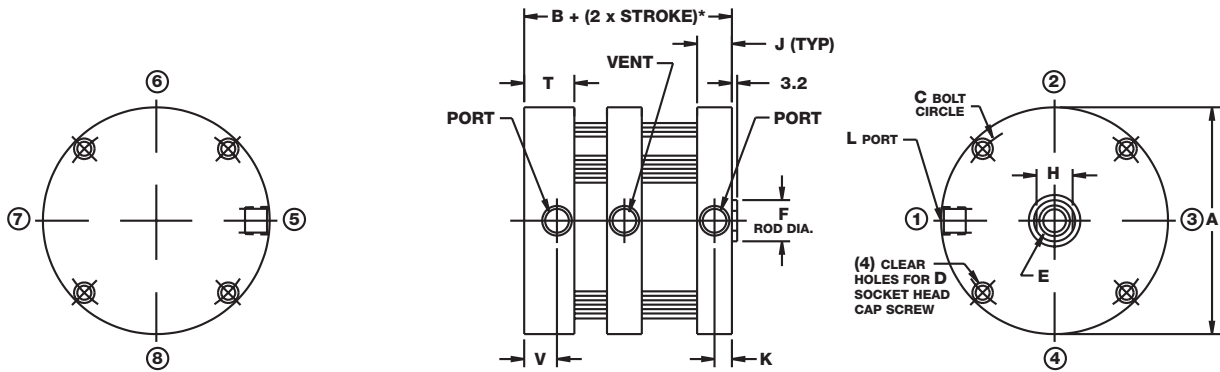

Model FM3

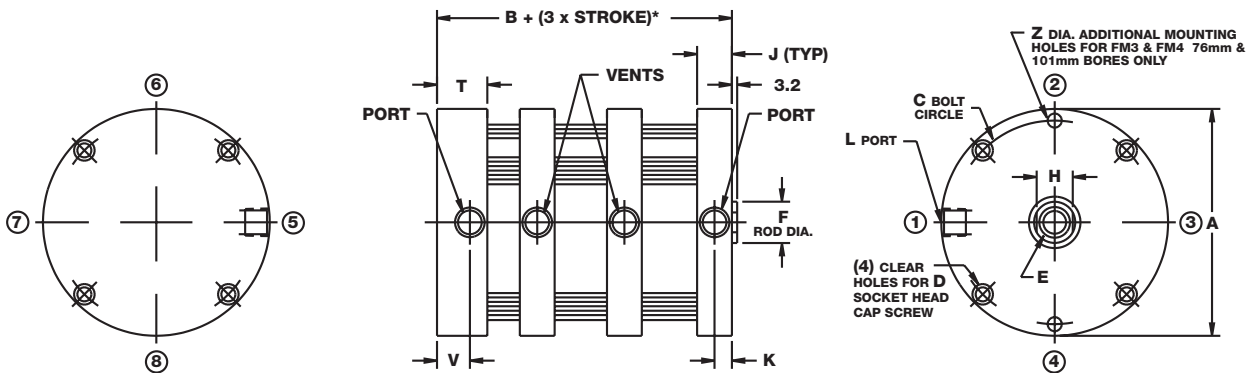

Model FM4

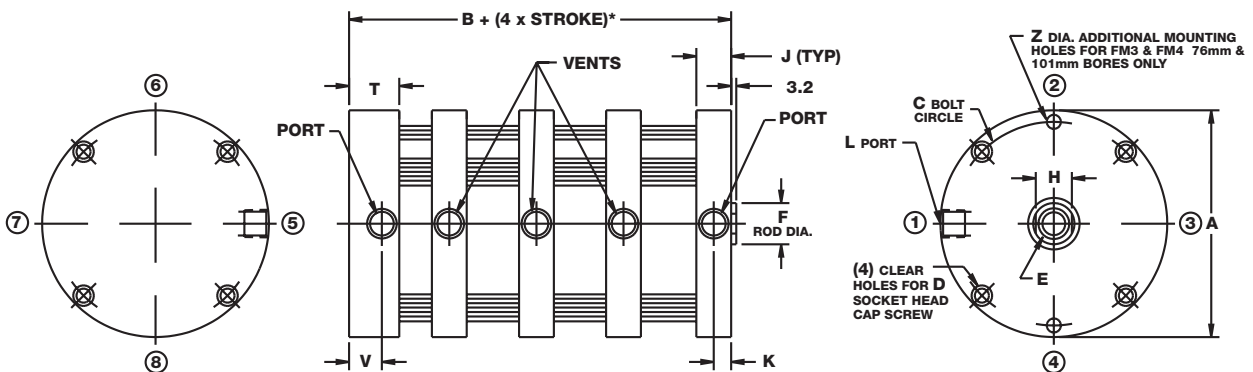

Dimensions(mm)

Bore	A	B**			C	D	E Std.	E Fine	E Depth
		FM2	FM3	FM4					
63mm (50)	95.0	58.2	80.0	102.1	83.0	M6	M12	M12 x 1.25	17.8
76mm (70)	107.7	60.7	83.3	106.2	96.0	M6	M16	M16 x 1.5	18.5
101mm (125)	139.5	77.2	105.4	133.9	125	M8	M20	M20 x 1.5	20.3

Bore	F	H	J	K	L	R	T	V	X	Z
63mm (50)	19.1	16.0	16.7	8.3	R 1/8	M6	23.0	14.7	10.5	N/A
76mm (70)	22.2	19.0	17.5	8.3	R 1/8	M6	23.8	14.7	10.5	7.1
101mm (125)	25.4	22.0	21.4	10.7	R 1/4	M8	31.0	19.1	13.5	8.6

*See page 3.25 for length adders for options.

****For Strokes 3.2 and .5**

Bore	Type	"B"	
		Stroke	
		3.175	6.350
63mm (50)	FM2	67.3	70.4
	FM3	92.5	98.3
	FM4	117.6	126.2
76mm (70)	FM2	69.9	73.2
	FM3	95.8	101.9
	FM4	121.7	130.8
101mm (125)	FM2	85.9	89.7
	FM3	117.1	124.2
	FM4	148.6	158.5

Mounting Options

Threaded Mounting Holes

(available either or both ends)
(-3R shown)

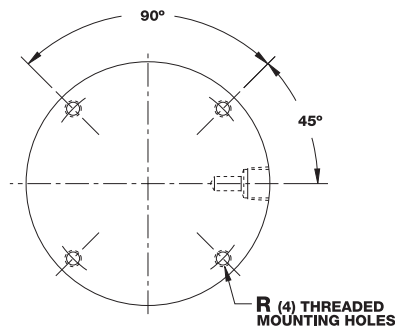

Screw Clearance Holes

(available either or both ends)
(-4R shown)

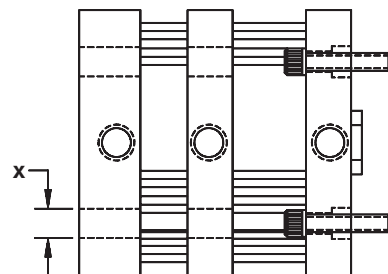

ISO 6431

ISO 6432

Flat

Pneu-Turn

Ultran

Flow Control

Position Sensing Solutions

Repair Kits

Basic Repair Kit (K-B-FM__)*		
Part No.	Description	Quantity**
PF-1	Rod Seal	2, 3 or 4
PF-2	Piston Seal	2, 3 or 4
PF-3	Tube Seal	3, 4 or 5
PF-4	Bushing	3, 4 or 5

*Must specify model and bore size when ordered.

**Quantities listed correspond with FM2, FM3 or FM4.

Wiper Option Repair Kit (K-B-FM__-W)*		
Part No.	Description	Quantity**
PF-1	Rod Seal	2, 3 or 4
PF-2	Piston Seal	2, 3 or 4
PF-3	Tube Seal	3, 4 or 5
PF-4	Bushing	3, 4 or 5
PF-5	Wiper Bushing	1
PF-6	Wiper	1

Weights

Bore	Approximate Cylinder Weights (gms)					
	Base			Adder per 5mm of stroke		
	FM2	FM3	FM4	FM2	FM3	FM4
63mm (50)	1055	1511	1967	53.5	80.2	71.4
76mm (70)	1415	2013	2611	71.4	107.0	142.7
101mm (125)	2640	3793	4947	89.1	133.7	178.3



The Bimba Metric Multiple Position FMP Flat-1 is a double-acting, single rod end cylinder that provides three positions with just one cylinder.*

- Body — 4301 Stainless Steel (X5 CrNi 18.9)
- Heads—Anodized Aluminum Alloy
- Piston Rod — Ground and Polished 4305 Stainless Steel (X12 CrNi S18.8)
- Seals — Buna N (High temperature seals optional)
- Rod Bushing — Oil Impregnated Bronze
- Pressure Rating — 14 Bar Maximum (Air only)
- Temperature Rating — From -25°C to +65°C

Buna N seals with a temperature range of -25°C to +65°C are standard in all Bimba air cylinders. Fluoroelastomer seals rated for higher temperature applications are available. If cylinders are operated at temperatures below -18°C for extended time periods, special modifications may be required. Special seal materials are available on request.

**Other positions (4, 5, etc.) are available as specials. Contact your local Bimba distributor for more information.*

ISO 6431

ISO 6432

Flat

How it Works

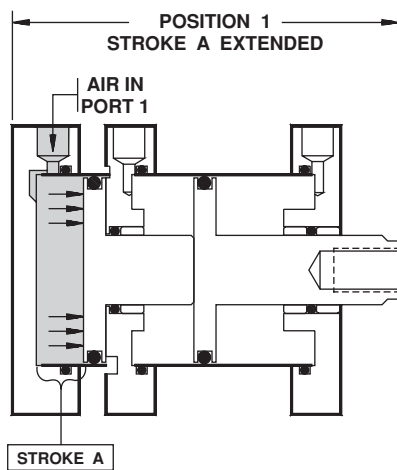

Position 1
Air is supplied to Port 1, cylinder extends stroke length A.

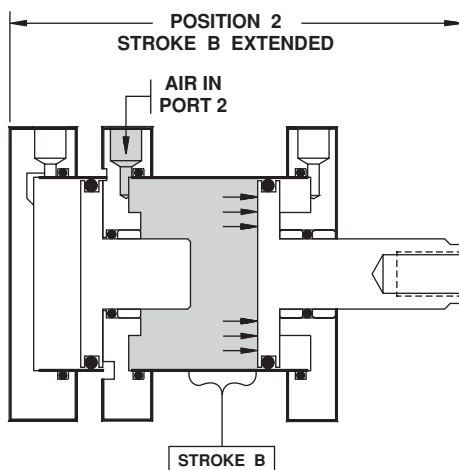

Position 2
Air is supplied to Port 2, cylinder extends stroke length B.

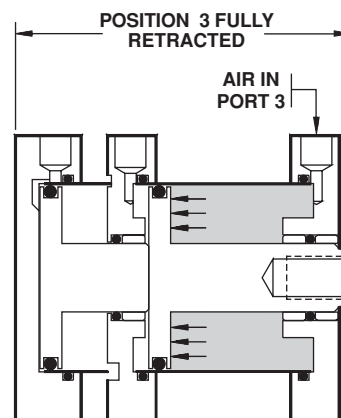

Position 3
Cylinder is fully retracted by supplying air to Port 3.

Note: For Magnetic Position Sensing option, magnet is mounted only on the piston of the Stroke B side.

Pneu-Turn

Ultran

Flow Control

Position Sensing Solutions

How to Order

The model number for all Metric Multiple Position FMP Flat-1 cylinders consists of three alphanumeric clusters. The first cluster designates type, the second cluster bore size and stroke lengths A and B, and the third cluster designates mounting and special options. Please refer to the charts below for an example of Model Number FMP-1750/25-1V. This is a 38mm bore multiple position FMP Flat-1 with a 50mm stroke for position A, plus an **additional** stroke of 25mm for position B, with a pivot mount on the rear head and high temperature option.

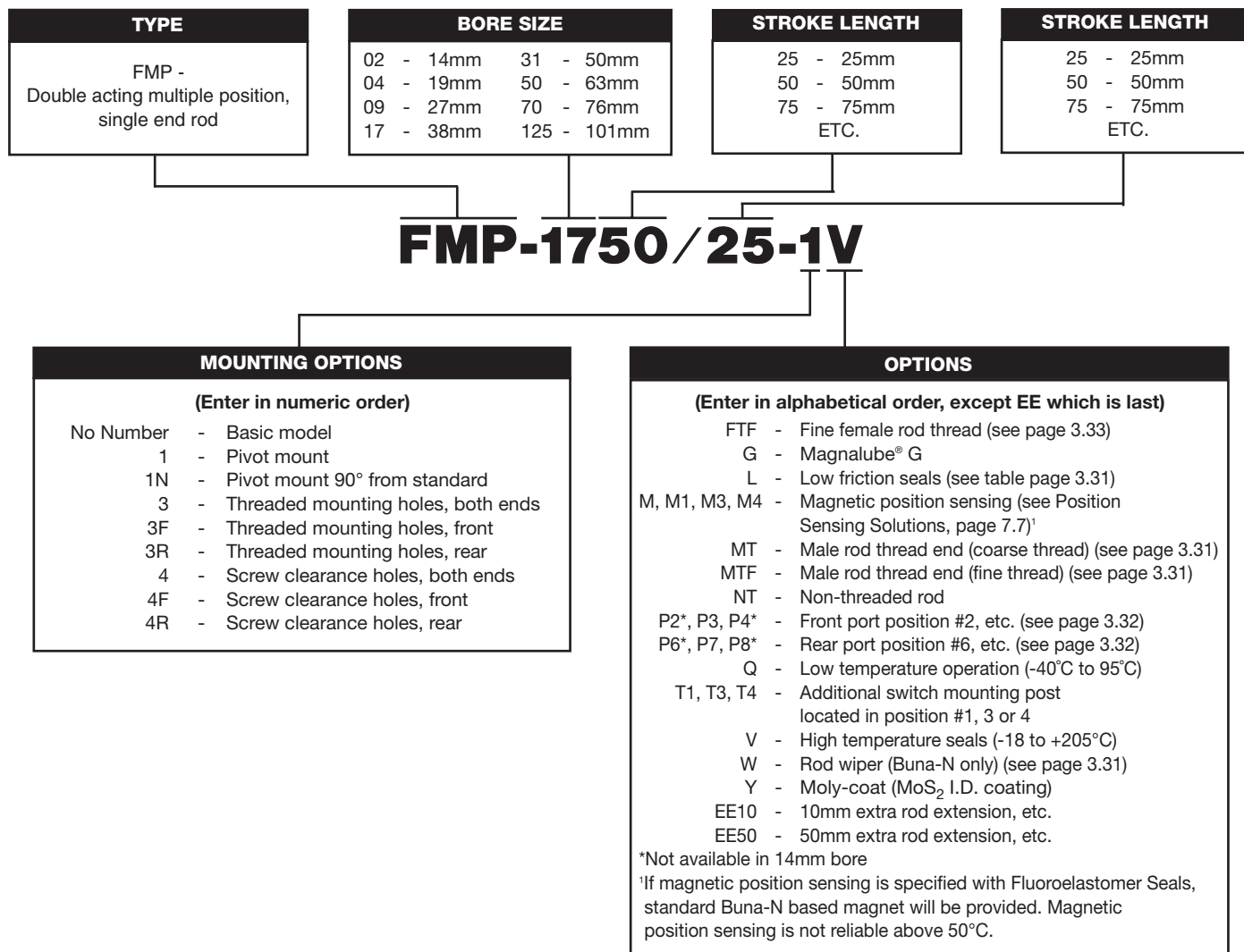

Magnalube® is a trademark of Carleton-Stuart Company.

Options(mm)

(Dimensional variations from standard as shown.)

Length Adder			
Bore	Low Friction Seals (L)	Magnetic Position Sensing* (M)	Low Friction Seals and Magnetic Position Sensing
14mm (02), 19mm (04)	12.7	22.2	28.6
27mm (09), 38mm (17), 50mm (31), 63mm (50)	19.1	22.2	31.8
76mm (70), 101mm (125)	25.4	22.2	34.9

*A minimum stroke of 9.5mm is required to sense extending end-of-stroke position.

Minimum Stroke

Model \ Bore	14mm	19mm	27mm	38mm	50mm	63mm	76mm	101mm
BASE MODEL STROKE A	4.8	4.8	6.4	6.4	6.4	9.5	9.5	8.7

No minimum for stroke B.

No minimum for stroke A or B with low friction seal option.

Rod Wiper (Option W)

(Buna N standard, not available in Viton)

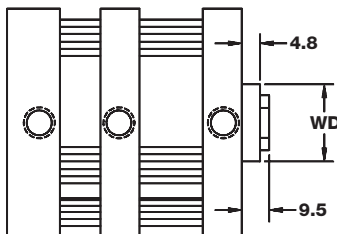

Bore	WD
14mm (02)	14.3
19mm (04)	17.5
27mm (09)	22.2
38mm (17)	25.4
50mm (31) 63mm (50)	28.6
76mm (70)	31.8
101mm (125)	34.9

Male Rod Ends (Option MT or MTF)

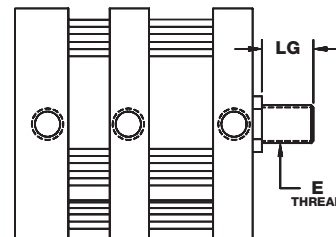

Bore	E		LG
	MT	MTF	
14mm (02)	M4	M4 x 0.5	10
19mm (04)	M5	M5 x 0.5	10
27mm (09)	M8	M8 x 1.0	12
38mm (17)	M10	M10 x 1.25	12
50mm (31) 63mm (50)	M12	M12 x 1.25	16
76mm (70)	M16	M16 x 1.5	20
101mm (125)	M20	M20 x 1.5	20

ISO 6431

ISO 6432

Flat

Pneu-Turn

Ultra

Flow Control

Position Sensing Solutions

Basic Model

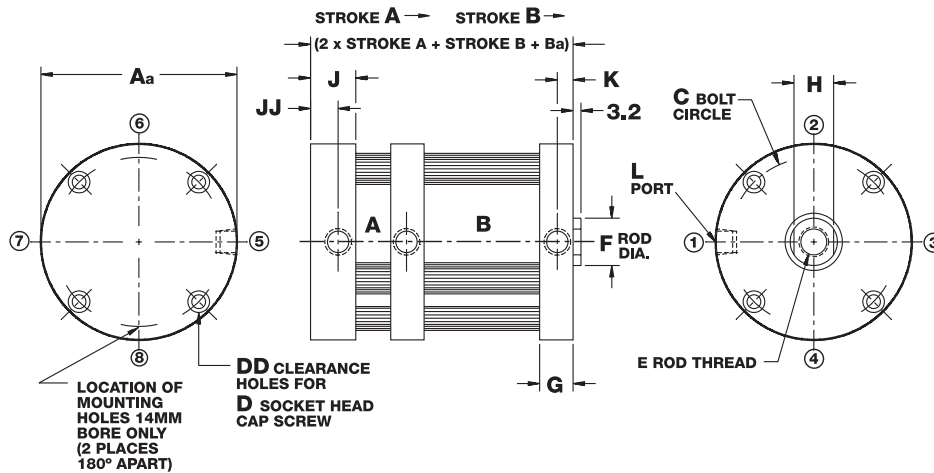

Mounting Options

Pivot Mount

(-1 shown) Complete with bronze pivot bushing. (Not available as an accessory)

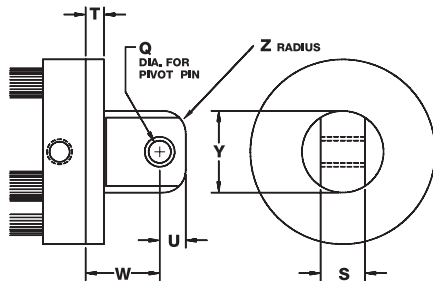

Screw Clearance Holes

(available either or both ends)
 (-4R shown) Screw clearance holes standard on all center sections

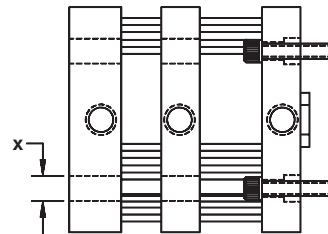

Threaded Mounting Holes

(available either or both ends)
 (-3R shown)

14mm Bore

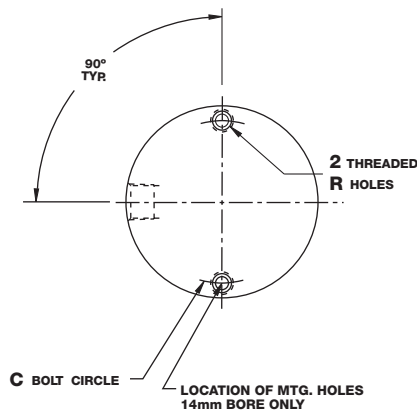

19mm Bore and larger

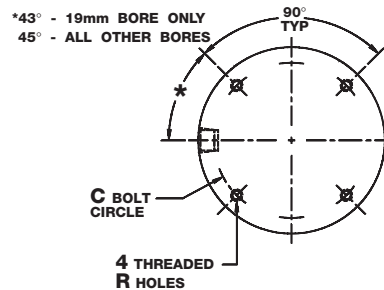

Dimensions(mm)

Bore	Aa	Ba*	C	DD	D	E (Std)	E (Fine)
14mm (02)	28.5	29.0	22.5	2	M3	M4	M4 x 0.5
19mm (04)	38.0	29.0	31.0	4	M3	M5	M5 x 0.5
27mm (09)	50.6	42.5	43.0	4	M3	M8	M8 x 1.0
38mm (17)	66.4	43.3	56.0	4	M5	M10	M10 x 1.25
50mm (31)	79.1	45.6	68.0	4	M5	M12	M12 x 1.25
63mm (50)	95.0	57.2	83.0	4	M6	M12	M12 x 1.25
76mm (70)	107.7	59.5	96.0	4	M6	M16	M16 x 1.5
101mm (125)	139.5	76.2	125.0	4	M8	M20	M20 x 1.5

Bore	E DEPTH	F	G	H	J	JJ	K	L
14mm (02)	11.7	6.3	8.7	5.5	11.9	6.8	3.6	M5
19mm (04)	11.7	7.9	8.7	6.0	11.9	6.8	3.6	M5
27mm (09)	17.8	12.7	12.7	11.0	17.5	11.1	6.4	G 1/8
38mm (17)	17.8	15.9	12.7	12.0	17.5	11.1	6.4	G 1/8
50mm (31)	17.8	19.1	13.5	16.0	18.3	11.1	6.4	G 1/8
63mm (50)	17.8	19.1	16.7	16.0	23.0	14.7	8.3	G 1/8
76mm (70)	18.5	22.2	17.5	19.0	23.8	14.7	8.3	G 1/8
101mm (125)	20.3	25.4	21.4	22.0	31.0	20.2	10.7	G 1/4

Bore	Q	R	S	T	U	W	X	Y	Z
14mm (02)	5	M3	9.5	5	6.5	19	6	16	5
19mm (04)	5	M3	9.5	5	6.5	19	6	19	5
27mm (09)	5	M3	9.5	6.5	6.5	20.5	6	19	5
38mm (17)	10	M5	19	6.5	11.5	30	9	35	9.5
50mm (31)	10	M5	19	8	11	32	9	35	9.5
63mm (50)	10	M6	19	9.5	11	33.5	10.5	35	9.5
76mm (70)	16	M6	25.5	9.5	14	43	10.5	47.5	9.5
101mm (125)	16	M8	25.5	11	14.5	44.5	13.5	47.5	9.5

*See page 3.31 for length adders for options.

ISO 6431

ISO 6432

Flat

Pneu-Turn

Ultran

Flow Control

Position
Sensing Solutions

Repair Kits

Basic Repair Kit (K-B FOP)*		
Part No.	Description	Quantity
PF-1	Rod Seal	2
PF-2	Piston Seal	2
PF-3	Tube Seal	3
PF-4	Bushing	3

**Must specify bore size when ordered. Contact your local Bimba distributor for pricing on kits and other repair parts.*

Wiper Option Repair Kit (K-B-FOP-W)*		
Part No.	Description	Quantity
PF-1	Rod Seal	2
PF-2	Piston Seal	2
PF-3	Tube Seal	3
PF-4	Bushing	2
PF-5	Wiper Bushing	1
PF-6	Wiper	1

Weights

Bore	Approximate Cylinder Weights (gms)	
	Base	Adder per 5mm of stroke
14mm (02)	94	7.1
19mm (04)	128	9
27mm (09)	281	26.7
38mm (17)	530	35.5
50mm (31)	695	44.6
63mm (50)	1170	53.4
76mm (70)	1500	71.4
101mm (125)	2912	89.1

Accessories(mm)

(All Models)

Selection Guide

Accessory	Flat-1	Square Flat-1	Square Flat-II	Flat-II	FM2 Series	FMP
Clevis Bracket	X	X	X	X	N/A	X
Trunnion Bracket	X	N/A	N/A	X	N/A	N/A
Rod Pivot	X	X	N/A	N/A	X	X

Clevis Bracket

Anodized aluminum alloy, complete with chrome plated steel pin

Model	Bore	LD	MT	Q	S	SH	SD	TH	TL
BCM-1	14mm (02) 19mm (04) 27mm (09)	14.5	19	5	10	3	25.5	4	20
BCM-2	38mm (17) 50mm (31) 63mm (50)	24	35	10	19.5	4	44.5	5.5	34
BCM-3	76mm (70) 101mm (125)	32	50	16	26	6	63.5	6.5	46

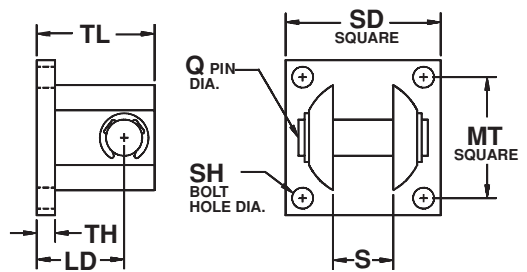

Bracket intended to mount with either rod pivot or pivot mount, not directly to the cylinder rear head.

Trunnion Bracket (pair)

Anodized aluminum alloy, complete with bronze pivot bushings

Model	Bore	BA	BT	HT	LT	M	N	NA	NB
BTM-1	19mm (04)	14.5	4	15.5	28.5	8	3	8	5.5
BTM-2	27mm (09) 38mm (17) 50mm (31)	20.5	6	22	38	12.5	6	10	8
BTM-3	63mm (50) 76mm (70)	24	8	25	41.5	16	8	12	9.5
BTM-4	101mm (125)	27	10	31.5	47.5	19	10	14	11

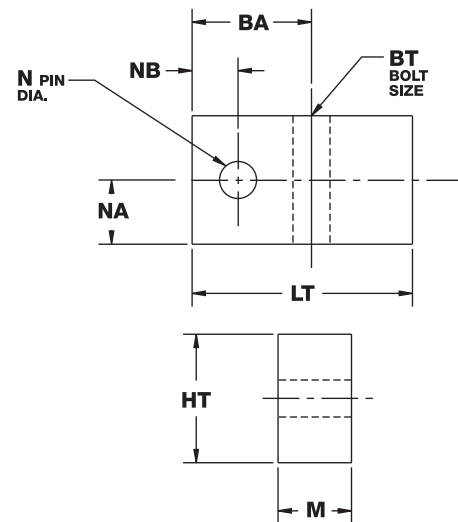

Rod Pivot

Zinc plated, high strength, heat treated alloy steel, complete with a bronze pivot bushing and nut

Model	Bore	E	LN	MS	NT	Q	S
RPM-1/2	14mm (02)	M4	9.5	11.5	6.5	5	9.5
RPM-1	19mm (04)	M5	9.5	11.5	6.5	5	9.5
RPM-2	27mm (09)	M8	16	11.5	6.5	5	9.5
RPM-3	38mm (17)	M10	16	18.5	11	10	19
RPM-4	50mm (31) 63mm (50)	M12	19	18.5	11	10	19
RPM-5	76mm (70)	M16	22.5	25.5	16	16	25.5
RPM-6	101mm (125)	M20	22.5	25.5	16	16	25.5

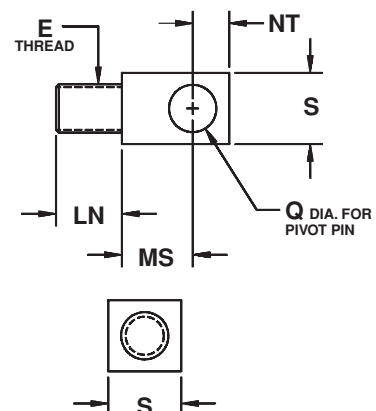

ISO 6431

ISO 6432

Flat

Pneu-Turn

Ultran

Flow Control

Position Sensing Solutions

